

Lifting Elements
Tragelemente
Elementi di sollevamento



OMCR[®]
STANDARD DIE COMPONENTS

Lifting Elements Tragelemente Elementi di Sollevamento

Ⓢ Safety is the password of **Lifting Elements**: all components of this series are designed and manufactured within **OMCR**, rigorously respecting an established procedure in order to guarantee the conformity of the item. The range offered is capable of satisfying every need in moving dies of every dimension and weight, in total safety. The **EC mark**, required by the **Directive Machine 2006/42/EC** for all producers of “lifting accessories” foresees many documents including Use and Maintenance manual and Conformity Certification. Customers can find these on our website: **www.omcr.it**.

Ⓢ Sicherheit lautet das Schlagwort der Linie **Tragelemente**: Alle Teile aus dieser Serie werden komplett bei **OMCR** nach den strengen Verfahren zur Gewährleistung der Konformität des Produkts hergestellt. Die Produktpalette erfüllt alle Anforderungen zum Transport von Werkzeugen in allen Größen und Gewichten in absoluter Sicherheit. Die **CE-Markierung**, die mit der **Maschinenrichtlinie 2006/42/CE** von allen Herstellern von Lastaufnahmemitteln verlangt wird, sieht eine Reihe von Unterlagen vor, darunter die Betriebs- und Instandhaltungsanleitung und die CE-Konformitätserklärung, die die Kunden von unserer Website **www.omcr.it** herunterladen können.

Ⓢ Sicurezza è la parola d'ordine della **Linea Elementi di Sollevamento**: tutti i particolari di questa serie sono realizzati all'interno di **OMCR** rispettando rigorosamente le procedure stabilite per garantire la conformità del prodotto. La gamma proposta è in grado di soddisfare tutte le esigenze di movimentazione stampi di ogni dimensione e peso, nella più totale sicurezza. La marcatura **CE**, richiesta dalla **Direttiva Macchine 2006/42/CE** a tutti i costruttori di “accessori di sollevamento” prevede una serie di documenti, fra cui il libretto di uso e manutenzione e il certificato di conformità, a disposizione dei clienti sul nostro sito: **www.omcr.it**.







OMCR S.p.A. - Via Garibaldi, 6 - 10077 S. Maurizio C.so - (Torino) Italy
Tel. +39 011 51 11 11 - Fax +39 011 51 11 12
E-mail: info@omcr.it - www.omcr.it

OMCR
OMCR S.p.A. - Via Garibaldi, 6 - 10077 S. Maurizio C.so - (Torino) Italy

EC CONFORMITY DECLARATION

OMCR S.p.A. seated in Via Garibaldi, 6 - 10077 S. Maurizio C.so - (Torino) Italy through its legal representative manager, declares that:

LIFTING PIN

OMCR articles: **B02.10 - B02.11 - B02.12 - B02.14 - B02.16 - B02.20 - B02.21 - B02.22 - B02.23 - B02.25 - B02.26 - B02.30 - B02.35 - B02.40 - B02.42 - B02.44**

Have a work under number (indicated on every model). It is possible to find out the documents filed in the Technical Office, to identify each manufacturing and inspection feature of the product. All the quality and safety procedures are arranged by M. Bernocchi, responsible of the technical file sitting in OMCR Via Garibaldi, 6, 10077 San Maurizio C.so. These procedures have been exactly issued to allow OMCR mark with EC symbol to ensure that these products:

- are in compliance with the established conditions from Directive 2006/42/EC of 6.2006
- are tested and certified as far as possible also with the harmonized and relevant CE Marks, the European Directives and the Italian safety legislations in use.

Before using lifting pins and lifting breakers, please read carefully the "Use and maintenance manual".

An importer or approved user in reference to the prescriptions treated in this manual, declares this EC conformity declaration and releases OMCR from any responsibility.

President of the legal file and Technical Office
 M. Bernocchi, responsible
 in name of OMCR S.p.A.
 the legal representative

OMCR S.p.A.
 legal representative
 Dimensione Aziendale

Via Garibaldi, 6 - 10077 S. Maurizio C.so - (Torino) Italy - Tel. +39 011 51 11 11 - Fax +39 011 51 11 12 - E-mail: info@omcr.it

Lifting Elements

CE

conformity



WARNING - ANMERKUNG - AVVERTENZA

- Ⓒ For safety reasons a die should be lifted with only two lifting elements.
- Ⓓ Aus Sicherheitsgründen stets berücksichtigen, dass zwei Tragwagen das gesamte Werkzeuggewicht tragen müssen.
- Ⓘ Per ragioni di sicurezza considerare sempre che il peso dello stampo deve essere sopportato da due soli elementi di sollevamento.

WARNING - ANMERKUNG - AVVERTENZA

- Ⓒ Make sure the die load centre is as symmetrical to the lifting fixtures as possible.
- Ⓓ Bei der Konstruktion sicherstellen, dass der Schwerpunkt des Werkzeugs so symmetrisch wie möglich zu den Tragelementen ist.
- Ⓘ In fase di progetto verificare che il baricentro dello stampo sia il più possibile simmetrico rispetto agli elementi di sollevamento.

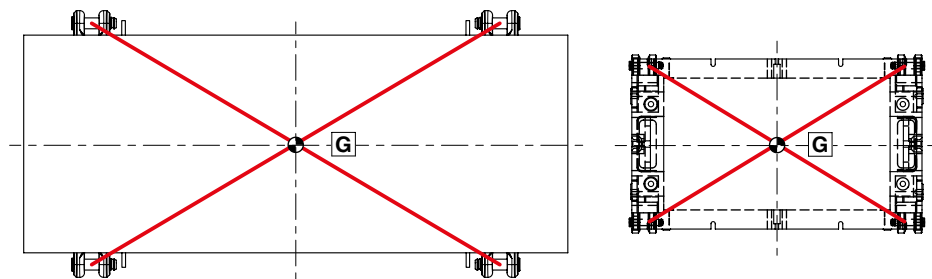

Pic.01

WARNING - ANMERKUNG - AVVERTENZA

- Ⓒ It is recommended to install a stop to prohibit an incorrect installation of pins.
- Ⓓ Wird die Verwendung von Sperren empfohlen, um eine nicht korrekte Einbringung der Tragbolzen zu verhindern.
- Ⓘ Si consiglia l'uso di barriere per impedire l'inserimento scorretto dei perni.

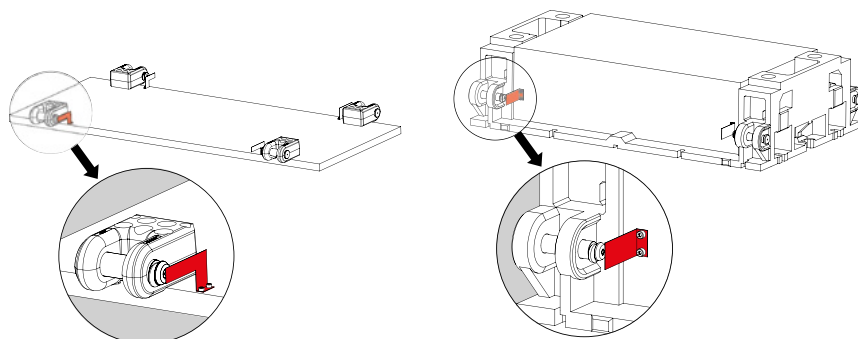

Pic.02

DIMENSIONING EXAMPLE - DIMENSIONIERUNGSBEISPIEL - ESEMPIO DI DIMENSIONAMENTO

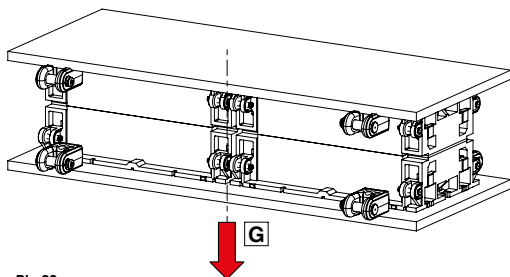

Pic.03

Die weight "G" = 36.000 kg
 $36.000/2 = 18.000$ kg
Use lifting bracket B01.20.18000

Gewicht Werkzeug "G" = 36.000 kg
 $36.000/2 = 18.000$ kg
Verwendung tragwange B01.20.18000

Peso stampo "G" = 36.000 kg
 $36.000/2 = 18.000$ kg
Utilizzare staffa B01.20.18000

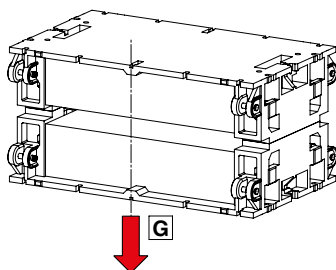

Pic.04

Die weight "G" = 25.000 kg
 $25.000/2 = 12.500$ kg
Use pin B02.10.063

Gewicht Werkzeug "G" = 25.000 kg
 $25.000/2 = 12.500$ kg
Tragbolzen B02.10.063

Peso stampo "G" = 25.000 kg
 $25.000/2 = 12.500$ kg
Utilizzare perno B02.10.063

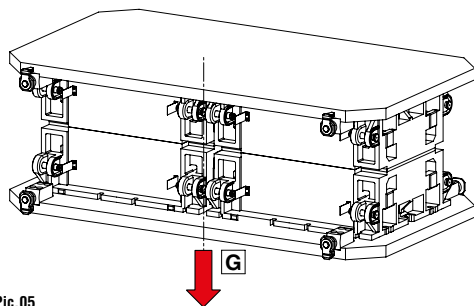

Pic.05

Die weight "G" = 16.000 kg
 $16.000/2 = 8.000$ kg
Use lifting bracket B01.11.063

Gewicht Werkzeug "G" = 16.000 kg
 $16.000/2 = 8.000$ kg
Verwendung tragwange B01.11.063

Peso stampo "G" = 16.000 kg
 $16.000/2 = 8.000$ kg
Utilizzare staffa B01.11.063

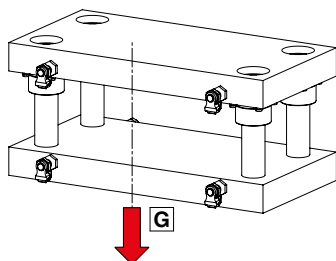

Pic.06

Die weight "G" = 3.000 kg
 $3.000/2 = 1.500$ kg
Use lifting pin B02.06.032

Gewicht Werkzeug "G" = 3.000 kg
 $3.000/2 = 1.500$ kg
Verwendung Tragschraube B02.06.032

Peso stampo "G" = 3.000 kg
 $3.000/2 = 1.500$ kg
Utilizzare perno B02.06.032

APPLICATIONS - ANWENDUNGEN - APPLICAZIONI

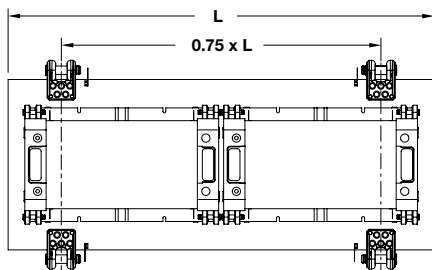

Pic.07

Ⓒ The **lifting brackets** should be positioned as shown in **Pic. 07**.

Ⓓ Die **Tragwangen** müssen gemäß der Darstellung auf **Pic. 07** positioniert werden.

Ⓘ Le **staffe** devono essere posizionate secondo lo schema rappresentato in **Pic. 07**.

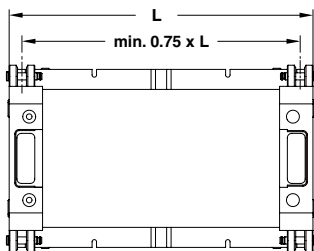

Pic.08

Ⓒ The **lifting pin** should be positioned as shown in **Pic. 08**.

Ⓓ Die **Tragbolzen** müssen gemäß der Darstellung auf **Pic. 08** positioniert werden.

Ⓘ I **perni** devono essere posizionati secondo lo schema rappresentato in **Pic. 08**.

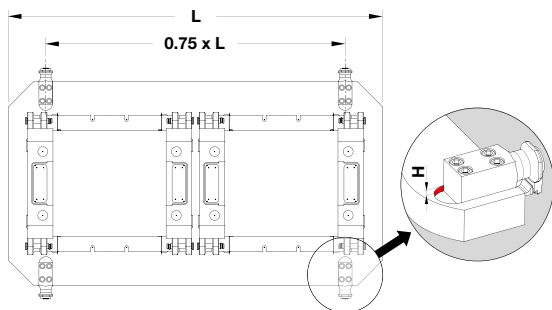

Pic.09

Ⓒ The **lifting brackets** should be positioned as shown in **Pic. 09** into the specific fixing-seats.

Ⓓ Die **Tragzapfen** müssen gemäß der Darstellung auf **Pic. 09** positioniert werden.

Ⓘ Le **staffe** devono essere posizionate secondo lo schema rappresentato in **Pic. 09** all'interno delle sedi d'incastro dedicate.

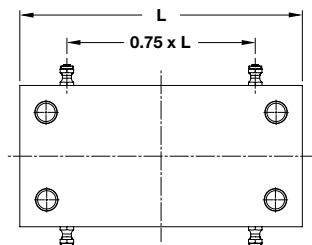

Pic.10

Ⓒ The **lifting pins** should be positioned as shown in **Pic. 10**.

Ⓓ Die **Tragschrauben** müssen gemäß der Darstellung auf **Pic. 10** positioniert werden.

Ⓘ I **perni** devono essere posizionati secondo lo schema rappresentato in **Pic. 10**.

TURNOVER - WENDEN - RIBALTAMENTO

- Ⓒ The die turnover is allowed only parallel with lifting pin axis.
- Ⓓ Das Wenden des Werkzeugs kann nur parallel zu den Achsen des Tragbolzen erfolgen.
- Ⓙ Il ribaltamento dello stampo può essere eseguito solo parallelamente all'asse del perno di sollevamento.

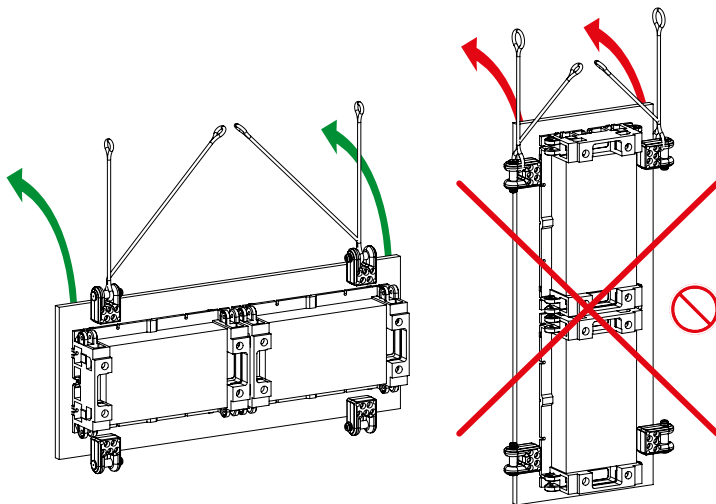

Pic.11

- Ⓒ The die turnover is allowed only parallel with lifting pin axis.
- Ⓓ Das Wenden des Werkzeugs kann nur parallel zu den Achsen des Tragbolzen erfolgen.
- Ⓙ Il ribaltamento dello stampo può essere eseguito solo parallelamente all'asse del perno di sollevamento.

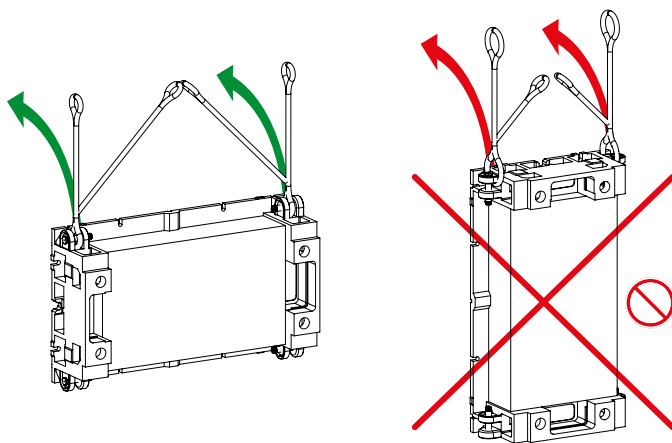

Pic.12

TURNOVER - WENDEN - RIBALTAMENTO

- Ⓒ The die turnover is allowed only parallel with lifting bracket axis.
- Ⓓ Das Wenden des Werkzeugs kann nur parallel zu den Achsen des Tragzapfen erfolgen.
- Ⓙ Il ribaltamento dello stampo può essere eseguito solo parallelamente all'asse della staffa di sollevamento.

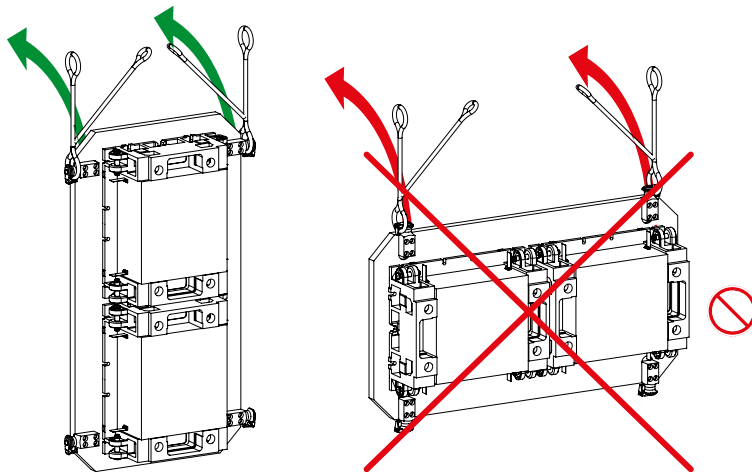

Pic.13

- Ⓒ The die turnover is allowed only parallel with lifting pin axis.
- Ⓓ Das Wenden des Werkzeugs kann nur parallel zu den Achsen des Tragschraube erfolgen.
- Ⓙ Il ribaltamento dello stampo può essere eseguito solo parallelamente all'asse del perno di sollevamento.

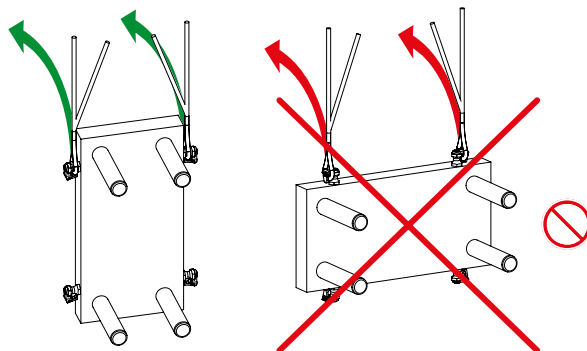







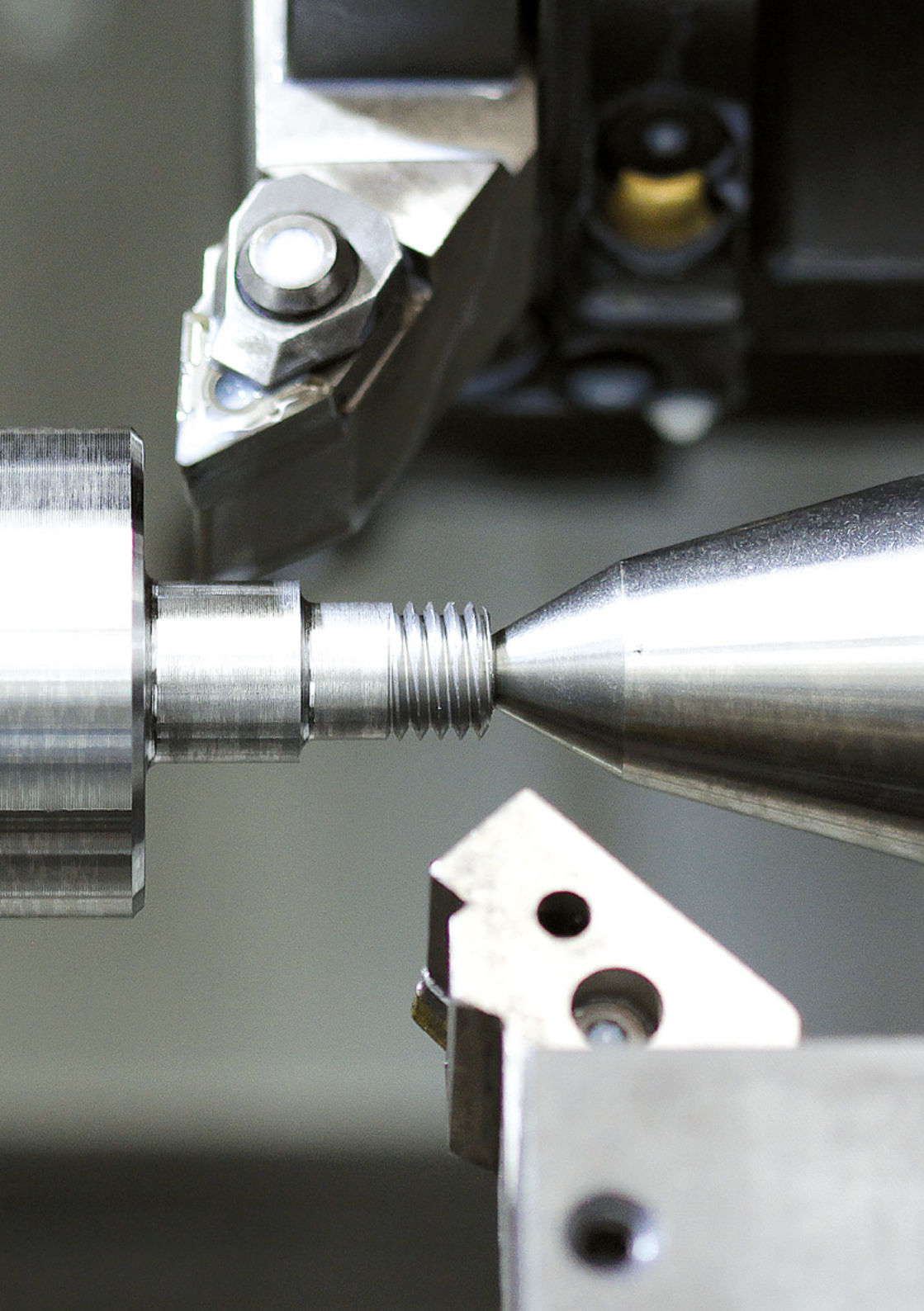



Pic.14

INFORMATION - INFORMATIONEN - INFORMAZIONI

- Ⓒ For more informations see the use and maintenance manuals available on: www.omcr.it.
- Ⓓ Weitere Informationen finden Sie in den Gebrauchs- und Instandhaltungsanleitungen auf unserer Internetseite www.omcr.it.
- Ⓙ Per maggiori informazioni consultare i manuali di uso e manutenzione disponibili sul nostro sito: www.omcr.it.



				
VDI 3366		BMW	FCA	RENAULT
Lifting bracket Tragzapfen Staffa di sollevamento	Lifting bracket with rope safety stop Tragzapfen mit Seilsicherung Staffa di sollevamento con sicurezza fermafune	Lifting bracket with rope safety stop Tragzapfen mit Seilsicherung Staffa di sollevamento con sicurezza fermafune	Lifting bracket with pin Tragwange mit Tragbolzen Staffa di sollevamento completa di perno	Lifting bracket with pin Tragwange mit Tragbolzen Staffa di sollevamento completa di perno
928	929	930	931	932
				
RENAULT	BMW	BMW	VW/AUDI	FOR REPLACEMENT ONLY VDI 3366 AT ROPS 124-935 FOR NEW DIES
Lifting bracket with pin Tragwange mit Tragbolzen Staffa di sollevamento completa di perno	Lifting bracket with pin Tragwange mit Tragbolzen Staffa di sollevamento completa di perno	Lifting bracket with pin Tragwange mit Tragbolzen Staffa di sollevamento completa di perno	Lifting bracket with pin Tragwange mit Tragbolzen Staffa di sollevamento completa di perno	Lifting bracket with pin Tragwange mit Tragbolzen Staffa di sollevamento completa di perno
933	934	935	936	937
				
VDI 3366		VDI 3366	VW	MERCEDES-BENZ
Lifting pin Tragschraube Perno di sollevamento	Lifting pin with rope safety stop Tragschraube mit Seilsicherung Perno di sollevamento con sicurezza fermafune	Lifting pin Tragbolzen Perno di sollevamento	Lifting pin Tragbolzen Perno di sollevamento	Lifting pin Tragbolzen Perno di sollevamento
938	939	940	941	942
				
FCA	FCA	FORD	NISSAN	OPEL - GM
Lifting pin Tragbolzen Perno di sollevamento	Lifting pin Tragbolzen Perno di sollevamento	Lifting pin Tragbolzen Perno di sollevamento	Lifting pin Tragbolzen Perno di sollevamento	Lifting pin Tragbolzen Perno di sollevamento
943	944	945	946	947

<p>B02.30</p> 	<p>B02.35</p> 	<p>B02.40</p> 	<p>B02.42</p> 	<p>B02.44</p> 
<p>PSA - RENAULT</p>	<p>VOLVO</p>	<p>BMW</p>	<p>FCA</p>	<p>VW/AUDI</p>
<p>Lifting pin Tragbolzen Perno di sollevamento</p>	<p>Lifting pin Tragbolzen Perno di sollevamento</p>	<p>Lifting pin Tragbolzen Perno di sollevamento</p>	<p>Lifting pin Tragbolzen Perno di sollevamento</p>	<p>Lifting pin Tragbolzen Perno di sollevamento</p>
<p>948</p>	<p>949</p>	<p>950</p>	<p>951</p>	<p>952</p>
<p>B03.10</p> 	<p>B03.15</p> 	<p>B03.20</p> 	<p>B08.11</p> 	<p>B08.20</p> 
<p>Rotating eyebolt H.T. Ringschraube H.T. Golfare girevole H.T</p>	<p>Rotating eyebolt with clamp Lastbock Golfare girevole con staffa</p>	<p>Rotating eyebolt with ring Wirbelbock Golfare girevole con anello</p>	<p>VDI - BAK</p>	<p>FCA - FORD</p>
<p>Rotating eyebolt H.T. Ringschraube H.T. Golfare girevole H.T</p>	<p>Rotating eyebolt with clamp Lastbock Golfare girevole con staffa</p>	<p>Rotating eyebolt with ring Wirbelbock Golfare girevole con anello</p>	<p>Bush for lifting pin Buchse für Tragbolzen Boccola per perno di sollevamento</p>	<p>Threaded Steel Insert Gewindeeinsatz für Guss Inserto filettato per fusione</p>
<p>954</p>	<p>956</p>	<p>958</p>	<p>960</p>	<p>961</p>
<p>B09.10</p>				
				
<p>Rope stop safety opening key Schlüssel für Seilsicherung Chiave per apertura sicurezza fermafune</p>				
<p>962</p>				

LIFTING BRACKET VDI 3366 TRAGZAPFEN VDI 3366 STAFFA DI SOLLEVAMENTO VDI 3366

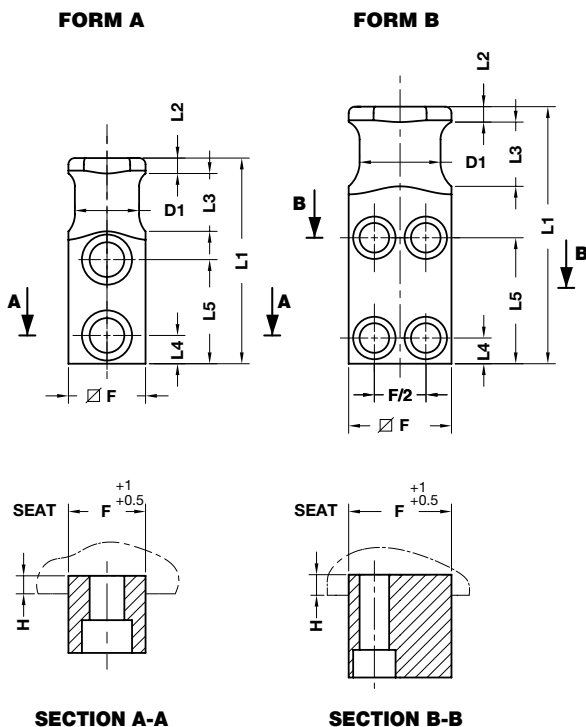

Respect the max load
Maximale Nutzlast beachten
Rispettare il carico Max

Screw the brackets on steel
(minimum quality Fe510 - S355)
Die Tragwangen auf Stahl
(mit Mindestqualität Fe510 - S355 verschrauben)
Avvitare le staffe su acciaio
(qualità minima Fe510 - S355)

WARNING - ACHTUNG - ATTENZIONE:
For safety reason, please consider always that the weight of the die has to be supported by just 2 lifting brackets.

Aus Sicherheitsgründen stets berücksichtigen, dass zwei Tragzapfens das gesamte Werkzeuggewicht tragen müssen.

Per ragioni di sicurezza, considerare sempre che il peso dello stampo deve essere supportato da 2 sole staffe.

Notes

Material: CK45 - 700÷800 N/mm²
Screws not included

ORDER EXAMPLE	Art.	D1=100
	B01.10.	100

OMCR CODE	Max load (kg)	Max die weight (kg)	D1	L1	L2	L3	L4	L5	F	H	FORM	Screws DIN 912 - 8.8
B01.10.016	320	640	16	80	6	20	10	44	20	6	A	M8x25
B01.10.020	630	1260	20	90	8	25	10	47	25	8	A	M10x30
B01.10.025	1250	2500	25	100	8	30	12	50	35	10	A	M12x40
B01.10.032	2000	4000	32	120	10	32	16	62	40	10	A	M16x45
B01.10.040	3200	6400	40	140	10	40	18	72	50	12	A	M20x60
B01.10.050	5000	10000	50	160	12	45	22	81	60	14	A	M24x70
B01.10.063	8000	16000	63	200	12	50	20	98	80	16	B	M20x90
B01.10.080	12500	25000	80	250	15	65	25	125	100	18	B	M24x110
B01.10.100	20000	40000	100	300	15	80	30	155	120	20	B	M30x130

LIFTING BRACKET WITH ROPE SAFETY STOP TRAGZAPFEN MIT SEILSICHERUNG STAFFA DI SOLLEVAMENTO CON SICUREZZA FERMAFUNDE

Patent-Nr.: TO2003A000468

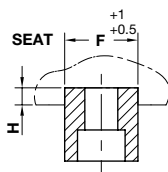
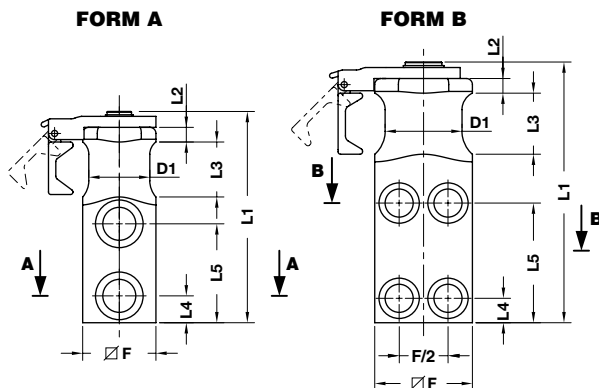

SECTION A-A

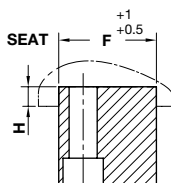

SECTION B-B

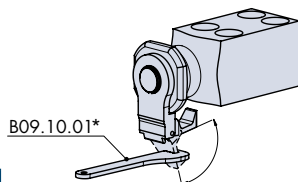
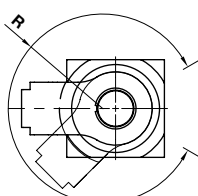
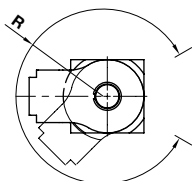

*To open rope stop safety use key B09.10.01

ORDER EXAMPLE	Art.	D1=50
	B01.11.	50



Respect the max load
Maximale Nutzlast beachten
Rispettare il carico Max

Screw the brackets on steel
(minimum quality Fe510 - S355)
Die Tragwangen auf Stahl
(mit Mindestqualität Fe510 - S355 verschrauben)
Avvitare le staffe su acciaio
(qualità minima Fe510 - S355)

WARNING - ACHTUNG - ATTENZIONE:

For safety reason, please consider always that the weight of the die has to be supported by just 2 lifting brackets.

Aus Sicherheitsgründen stets berücksichtigen, dass zwei Tragzapfens das gesamte Werkzeuggewicht tragen müssen.

Per ragioni di sicurezza, considerare sempre che il peso dello stampo deve essere sopportato da 2 sole staffe.

Notes

Material: CK45 - 700÷800 N/mm²
Screws not included

Lifting Elements

OMCR CODE	Max load (kg)	Max die weight (kg)	D1	L1	L2	L3	L4	L5	F	H	R	FORM	Screws DIN 912 - 8.8
B01.11.20	630	1260	20	99	8	25	10	47	25	8	38	A	M10x30
B01.11.25	1250	2500	25	112,5	8	30	12	50	35	10	42	A	M12x40
B01.11.32	2000	4000	32	132,5	10	32	16	62	40	10	52	A	M16x45
B01.11.40	3200	6400	40	152,5	10	40	18	72	50	12	60	A	M20x60
B01.11.50	5000	10000	50	173	12	45	22	81	60	14	66	A	M24x70
B01.11.63	8000	16000	63	213,5	12	50	20	98	80	16	80	B	M20x90

LIFTING BRACKET WITH ROPE SAFETY STOP TRAGZAPFEN MIT SEILSICHERUNG STAFFA DI SOLLEVAMENTO CON SICUREZZA FERMAFUNE

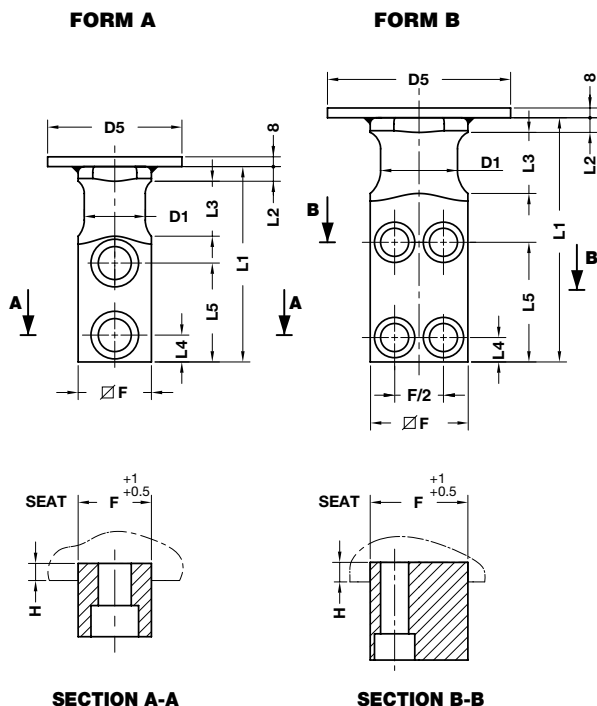

⚠

Respect the max load
Maximale Nutzlast beachten
Rispettare il carico Max

Screw the brackets on steel
(minimum quality Fe510 - S355)
Die Tragwangen auf Stahl
(mit Mindestqualität Fe510 - S355 verschrauben)
Avvitare le staffe su acciaio
(qualità minima Fe510 - S355)

WARNING - ACHTUNG - ATTENZIONE:
For safety reason, please consider always that the weight of the die has to be supported by just 2 lifting brackets.
Aus Sicherheitsgründen stets berücksichtigen, dass zwei Tragzapfens das gesamte Werkzeuggewicht tragen müssen.
Per ragioni di sicurezza, considerare sempre che il peso dello stampo deve essere supportato da 2 sole staffe.

Notes

Material: CK45 - 700÷800 N/mm²
Screws not included

ORDER EXAMPLE	Art.	D1=80
	B01.12.	080

OMCR CODE	Max load (kg)	Max die weight (kg)	D1	D5	L1	L2	L3	L4	L5	F	H	FORM	Screws DIN 912 - 8.8
B01.12.016	320	640	16	60	80	6	20	10	44	20	6	A	M8x25
B01.12.020	630	1260	20	70	90	8	25	10	47	25	8	A	M10x30
B01.12.025	1250	2500	25	70	100	8	30	12	50	35	10	A	M12x40
B01.12.032	2000	4000	32	110	120	10	32	16	62	40	10	A	M16x45
B01.12.040	3200	6400	40	110	140	10	40	18	72	50	12	A	M20x60
B01.12.050	5000	10000	50	150	160	12	45	22	81	60	14	A	M24x70
B01.12.063	8000	16000	63	150	200	12	50	20	98	80	16	B	M20x90
B01.12.080	12500	25000	80	150	250	15	65	25	125	100	18	B	M24x110
B01.12.100	20000	40000	100	150	300	15	80	30	155	120	20	B	M30x130

FCA LIFTING BRACKET WITH PIN TRAGWANGE MIT TRAGBOLZEN NACH FCA NORM STAFFA DI SOLLEVAMENTO TIPO FCA COMPLETA DI PERNO

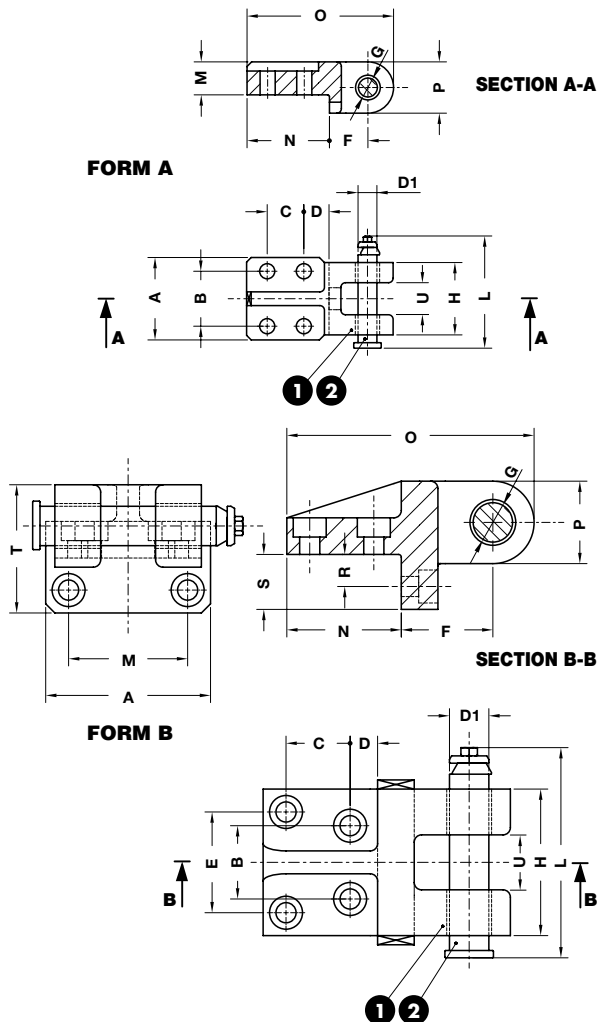

STOCK

WARNING - ACHTUNG - ATTENZIONE:

Respect the max load
Maximale Nutzlast beachten
Rispettare il carico Max

Screw the brackets on steel
(minimum quality Fe510 - S355)

Die Tragwangen auf Stahl
(mit Mindestqualität Fe510 - S355 verschrauben)

Avvitare le staffe su acciaio
(qualità minima Fe510 - S355)

For safety reason, please consider always that the weight of the die has to be supported by just 2 lifting brackets.

Aus Sicherheitsgründen stets berücksichtigen, dass zwei Tragzapfens das gesamte Werkzeuggewicht tragen müssen.

Per ragioni di sicurezza, considerare sempre che il peso dello stampo deve essere sopportato da 2 sole staffe.

Notes

1 Material: CK45
800 ÷ 1000 N/mm²

2 B02.42.

Screws not included

ORDER EXAMPLE	Art.	Max load
	B01.15.	7000

OMCR CODE	Max load (kg)	Max die weight (kg)	A	B	C	D	D1	E	F	G	H	L	M	N	O	P	R	S	T	U	FORM	Screws DIN 912 - 8.8
B01.15.0600	600	1200	80	50	40	22,5	15,6	-	39	16	70	102,5	32	80	145	52	-	-	-	30	A	M12x45
B01.15.1000	1000	2000	90	60	40	27,5	20,6	-	42	21	79	113,5	36	90	160	56	-	-	-	35	A	M16x55
B01.15.2000	2000	4000	100	65	65	32,5	25,6	-	60	26	90	128,5	50	120	215	70	-	-	-	40	A	M20x80
B01.15.4000	4000	8000	135	56	60	20	33	84	85	34	125	166,5	96	100	221	72	30	50	111	55	B	M16x45
B01.15.7000	7000	14000	180	80	70	30	43	110	100	44	160	210,5	130	125	270	90	35	60	140	60	B	M20x60

Lifting Elements

RENAULT LIFTING BRACKET WITH PIN TRAGWANGE MIT TRAGBOLZEN NACH RENAULT NORM STAFFA DI SOLLEVAMENTO TIPO RENAULT COMPLETA DI PERNO

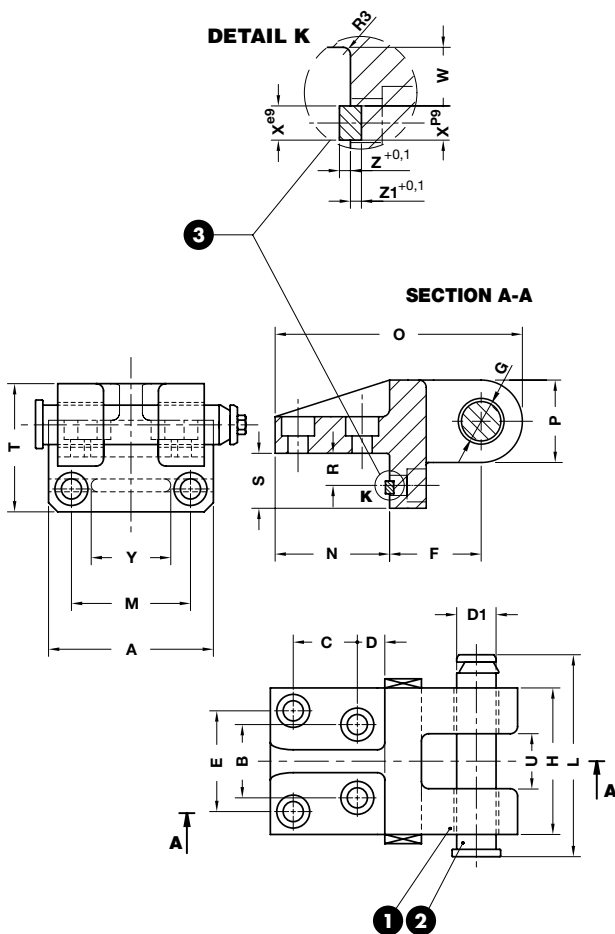

Respect the max load
Maximale Nutzlast beachten
Rispettare il carico Max

Screw the brackets on steel
(minimum quality Fe510 - S355)
Die Tragwangen auf Stahl
(mit Mindestqualität Fe510 - S355 verschrauben)
Avvitare le staffe su acciaio
(qualità minima Fe510 - S355)

WARNING - ACHTUNG - ATTENZIONE:
For safety reason, please consider always that the weight of the die has to be supported by just 2 lifting brackets.
Aus Sicherheitsgründen stets berücksichtigen, dass zwei Tragzapfens das gesamte Werkzeuggewicht tragen müssen.
Per ragioni di sicurezza, considerare sempre che il peso dello stampo deve essere supportato da 2 sole staffe.

Notes

- 1 **Material:** CK45
800 ÷ 1000 N/mm²
- 2 B02.30.
- 3 KEY DIN 6885

Screws not included

	Art.	Max load
	B01.16.	6300

OMCR CODE	Max load (kg)	Max die weight (kg)	A	B	C	D	D1	E	F	G	H	L	M	N	O	P	R	S	T	U	W	X	Y	Z	Z1	Screws DIN 912 - 8.8
B01.16.4000	4000	8000	135	56	60	20	32	84	85	33	125	154	96	100	221	72	30	50	111	55	24	14	63	4.5	4.5	M16x45
B01.16.6300	6300	12600	180	80	70	30	40	110	100	41	160	197,5	130	125	270	90	35	60	140	60	27	16	100	5	5	M20x60

RENAULT LIFTING BRACKET WITH PIN AND LOCATING PINS TRAGWANGE MIT TRAGBOLZEN UND ZENTRIERBOLZEN NACH RENAULT NORM STAFFA DI SOLLEVAMENTO TIPO RENAULT COMPLETA DI PERNO E CENTRAGGI

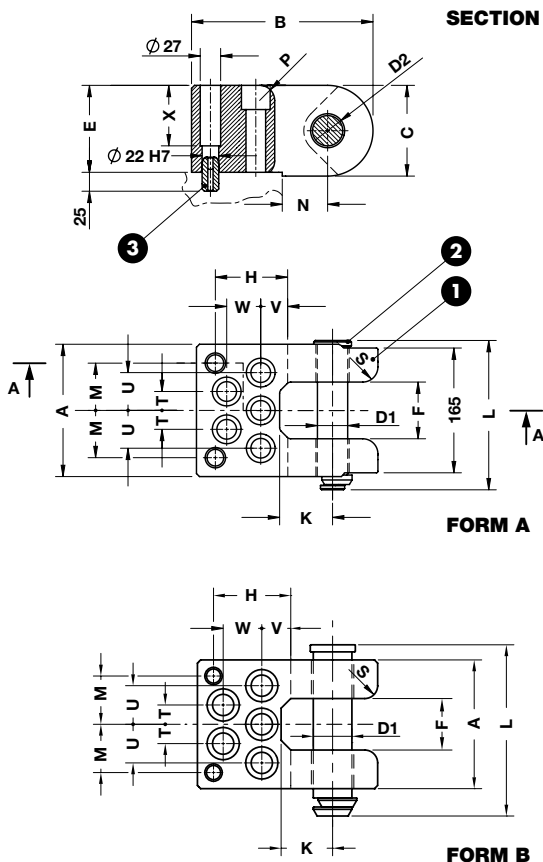

⚠

Respect the max load
Maximale Nutzlast beachten
Rispettare il carico Max

Screw the brackets on steel
(minimum quality Fe510 - S355)
Die Tragwangen auf Stahl
(mit Mindestqualität Fe510 - S355 verschrauben)
Avvitare le staffe su acciaio
(qualità minima Fe510 - S355)

WARNING - ACHTUNG - ATTENZIONE:
For safety reason, please consider always that the weight of the die has to be supported by just 2 lifting brackets.
Aus Sicherheitsgründen stets berücksichtigen, dass zwei Tragzapfens das gesamte Werkzeuggewicht tragen müssen.
Per ragioni di sicurezza, considerare sempre che il peso dello stampo deve essere sopportato da 2 sole staffe.

- Notes**
- 1 **Material:** St52
 - 2 B02.30.
 - 3 C11.20.2245 (2x)
Screws not included

ORDER SAMPLE	Art.	Max load
	B01.18.	12500

OMCR CODE	Max load (kg)	Max die weight (kg)	D1	D2	A	B	C	E	F	H	K	L	M	N	P	S	T	U	V	W	X	FORM	Screws DIN 912 - 8.8
B01.18.08000	8000	16000	40	42	175	240	120	115	75	95	70	197,5	62,5	60	20	24	25	50	35	45	80	A	M24x120
B01.18.12500	12500	25000	50	52	200	300	140	130	80	145	80	247,5	77,5	65	20	30	35	65	60	65	95	B	M36x160

BMW LIFTING BRACKET WITH PIN AND LOCATING PINS
TRAGWANGE MIT TRAGBOLZEN UND ZENTRIERBOLZEN NACH BMW NORM
STAFFA DI SOLLEVAMENTO TIPO BMW COMPLETA DI PERNO E CENTRAGGI

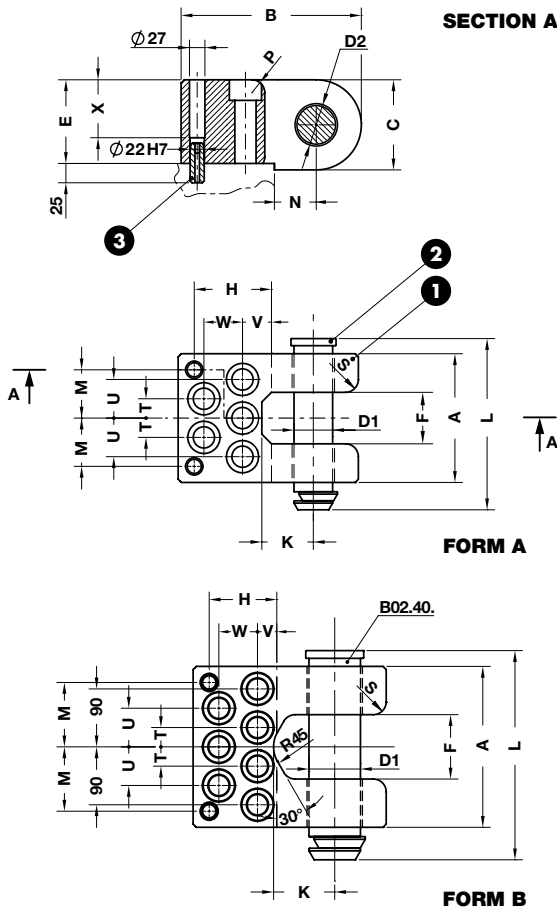

WARNING - ACHTUNG - ATTENZIONE:

Respect the max load
 Maximale Nutzlast beachten
 Rispettare il carico Max

Screw the brackets on steel
 (minimum quality Fe510 - S355)
 Die Tragwangen auf Stahl
 (mit Mindestqualität Fe510 - S355 verschrauben)
 Avvitare le staffe su acciaio
 (qualità minima Fe510 - S355)

For safety reason, please consider always that the weight of the die has to be supported by just 2 lifting brackets.
 Aus Sicherheitsgründen stets berücksichtigen, dass zwei Tragzapfens das gesamte Werkzeuggewicht tragen müssen.
 Per ragioni di sicurezza, considerare sempre che il peso dello stampo deve essere supportato da 2 sole staffe.

Notes

1 Material: St52
2 B02.40.
3 C11.20.2245 (2x)
 Screws not included

ORDER EXAMPLE	Art.	Max load
	B01.20.	18000

OMCR CODE	Max load (kg)	Max die weight (kg)	D1	D2	A	B	C	E	F	H	K	L	M	N	P	S	T	U	V	W	X	FORM	Screws DIN 912 - 8.8
B01.20.03200	3200	6400	30	32	126	185	80	75	50	85	50	158	45	40	12	16	20	40	30	35	40	A	M16x80
B01.20.05000	5000	10000	40	42	150	210	100	95	60	87	55	187	52	50	12	20	22,5	45	25	40	60	A	M20x100
B01.20.08000	8000	16000	50	52	175	240	120	115	75	95	70	220	62,5	60	16	24	25	50	35	45	80	A	M24x120
B01.20.12500A	12500	25000	60	62	200	300	140	130	80	145	80	246	77,5	65	20	30	35	65	60	65	95	A	M36x160
B01.20.18000	18000	36000	80	82	250	300	160	150	100	105	95	305	100	90	20	30	30	60	30	60	115	B	M30x160



BMW LIFTING BRACKET WITH PIN AND KEYS TRAGWANGE MIT TRAGBOLZEN UND PASSFEDER NACH BMW NORM STAFFA DI SOLLEVAMENTO TIPO BMW COMPLETA DI PERNO E CHIAVETTE

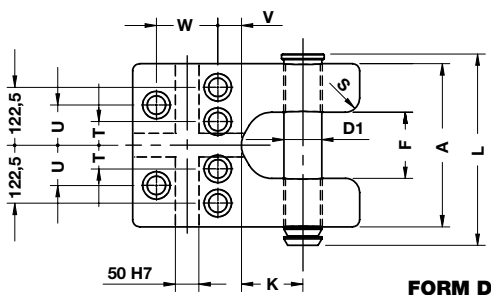
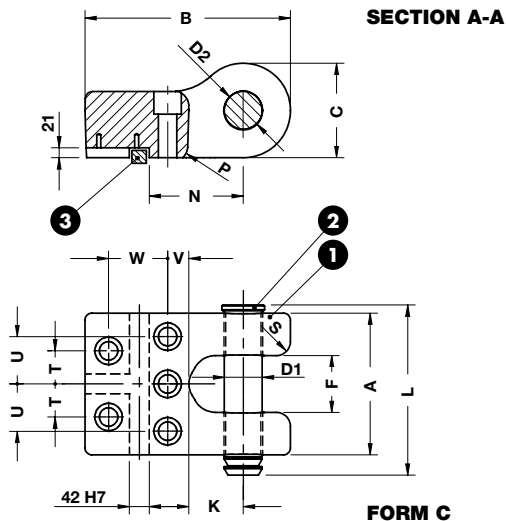

Respect the max load
Maximale Nutzlast beachten
Rispettare il carico Max

Screw the brackets on steel
(minimum quality Fe510 - S355)
Die Tragwangen auf Stahl
(mit Mindestqualität Fe510 - S355 verschrauben)
Avvitare le staffe su acciaio
(qualità minima Fe510 - S355)

WARNING - ACHTUNG - ATTENZIONE:

For safety reason, please consider always that the weight of the die has to be supported by just 2 lifting brackets.

Aus Sicherheitsgründen stets berücksichtigen, dass zwei Tragzapfens das gesamte Werkzeuggewicht tragen müssen.

Per ragioni di sicurezza, considerare sempre che il peso dello stampo deve essere sopportato da 2 sole staffe.

Notes

- 1 **Material:** St52
- 2 B02.40.
- 3 B01.20.25000: C14.20.42125 (3x)
B01.20.31500: C14.20.50135 (2x)
C14.20.50220 (1x)

Screws not included

ORDER SAMPLE	Art.	Max load
	B01.20.	31500

OMCR CODE	Max load (kg)	Max die weight (kg)	D1	D2	A	B	C	E	F	K	L	N	P	S	T	U	V	W	FORM	Screws DIN 912-8.8
B01.20.25000	25000	50000	80	82	300	435	200	140	120	115	360	199	30	30	70	100	45	125	C	M36x160 (5x)
B01.20.31500	31500	63000	80	82	345	480	240	170	135	130	405	220	30	30	50	85	50	130	D	M36x200 (6x)

VW/AUDI LIFTING BRACKET WITH PIN AND LOCATING PINS
TRAGWANGE MIT TRAGBOLZEN UND ZENTRIERBOLZEN NACH VW/AUDI NORM
STAFFA DI SOLLEVAMENTO TIPO VW/AUDI COMPLETA DI PERNO E CENTRAGGI

SECTION A-A

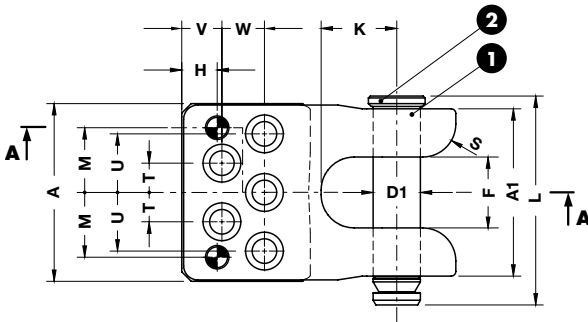
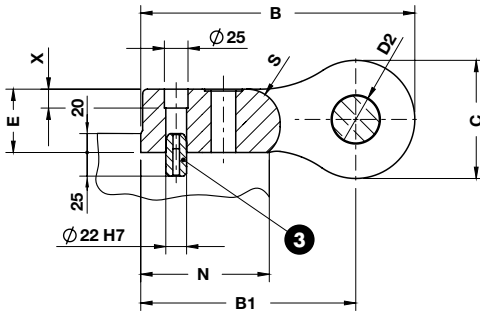

FORM A

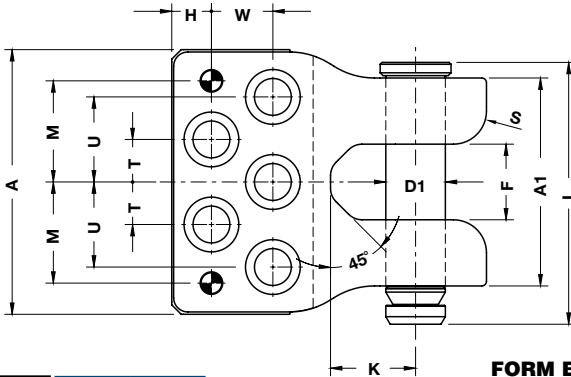

FORM B

⚠
 Respect the max load
 Maximale Nutzlast beachten
 Rispettare il carico Max

Screw the brackets on steel
 (minimum quality Fe510 - S355)
 Die Tragwangen auf Stahl
 (mit Mindestqualität Fe510 - S355 verschrauben)
 Avvitare le staffe su acciaio
 (qualità minima Fe510 - S355)

WARNING - ACHTUNG - ATTENZIONE:
 For safety reason, please consider always that the weight of the die has to be supported by just 2 lifting brackets.
 Aus Sicherheitsgründen stets berücksichtigen, dass zwei Tragzapfens das gesamte Werkzeuggewicht tragen müssen.
 Per ragioni di sicurezza, considerare sempre che il peso dello stampo deve essere sopportato da 2 sole staffe.

- Notes**
- 1 **Material:** St52
 - 2 B02.44.
 - 3 C11.20.2245
- Screws not included

ORDER SAMPLE	Art.	Max load
	B01.24.	12500

OMCR CODE	Max load (kg)	Max die weight (kg)	D1	D2	A	A1	B	B1	C	E	F	H	K	L	M	N	S	T	U	V	W	X	FORM	Screws DIN 912-8.8
B01.24.08000	8000	16000	50	52	188	177	290	227,5	125	67	75	37,5	80	221	68,5	135	35	31	62	42,5	45	20	A	M24x100
B01.24.12500	12500	25000	63	65	280	220	333	258	150	91	80	42	90	277	107	150	35	45	90	-	65	46	B	M36x120

VDI 3366 LIFTING BRACKET WITH PIN
TRAGWANGE MIT TRAGBOLZEN NACH VDI 3366 NORM
STAFFA DI SOLLEVAMENTO TIPO VDI 3366 COMPLETA DI PERNO

SECTION A-A

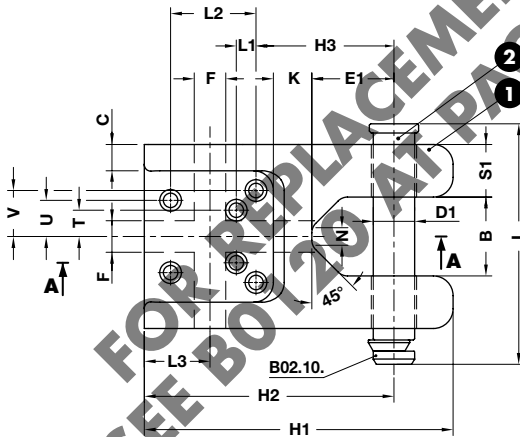
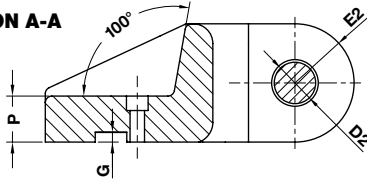

Respect the max load
 Maximale Nutzlast beachten
 Rispettare il carico Max

Screw the brackets on steel
 (minimum quality Fe510 - S355)
 Die Tragwangen auf Stahl
 (mit Mindestqualität Fe510 - S355 verschrauben)
 Avvitare le staffe su acciaio
 (qualità minima Fe510 - S355)

WARNING - ACHTUNG - ATTENZIONE:
 For safety reason, please consider always that the weight of the die has to be supported by just 2 lifting brackets.

Aus Sicherheitsgründen stets berücksichtigen, dass zwei Tragzapfens das gesamte Werkzeuggewicht tragen müssen.

Per ragioni di sicurezza, considerare sempre che il peso dello stampo deve essere sopportato da 2 sole staffe.

Notes

- 1** Material: St52
- 2** B02.10.

Screws not included

	Art.	Max load
	B01.25.	31500

OMCR CODE	Max load (kg)	Max die weight (kg)	D1	D2	B	C	E1	E2	F	G	H1	H2	H3	K	L	L1	L2	L3	P	S1	T	U	V	Screws DIN 912 - 8.8	
B01.25.03200	3200	6400	32	34	60	20	63	40	25	7	260	220	125	28	37	175	30	85	45	40	40	25	30	30	M12x40
B01.25.05000	5000	10000	40	42	80	30	80	60	48	15	360	300	140	28	40	225	35	130	80	60	50	38	40	43	M16x75
B01.25.08000	8000	16000	50	52	100	30	100	60	48	15	380	320	160	28	40	273	35	130	85	70	60	40	55	55	M16x85
B01.25.12500	12500	25000	63	65	120	40	125	90	48	15	470	380	210	28	60	347	30	130	100	70	80	40	55	70	M20x90
B01.25.18000	18000	36000	76	78	140	40	160	90	64	20	510	420	250	45	60	422	20	135	100	90	100	50	75	100	M24x115
B01.25.25000	25000	50000	76	78	140	40	160	120	64	25	590	470	270	45	80	422	35	160	110	110	100	55	75	100	M30x140
B01.25.31500	31500	63000	76	78	140	40	160	130	64	25	600	470	270	45	80	422	35	160	110	120	100	55	75	100	M30x150

LIFTING PIN VDI 3366 TRAGSCHRAUBE VDI 3366 PERNO DI SOLLEVAMENTO VDI 3366



Respect the max load
Maximale Nutzlast beachten
Rispettare il carico Max

WARNING - ACHTUNG - ATTENZIONE:

For safety reason, please consider always that the weight of the die has to be supported by just 2 lifting pins.

Aus Sicherheitsgründen stets berücksichtigen, dass zwei Tragschrauben das gesamte Werkzeuggewicht tragen müssen.

Per ragioni di sicurezza, considerare sempre che il peso dello stampo deve essere sopportato da 2 soli perni.

Notes

Material: CK45
700÷800 N/mm²

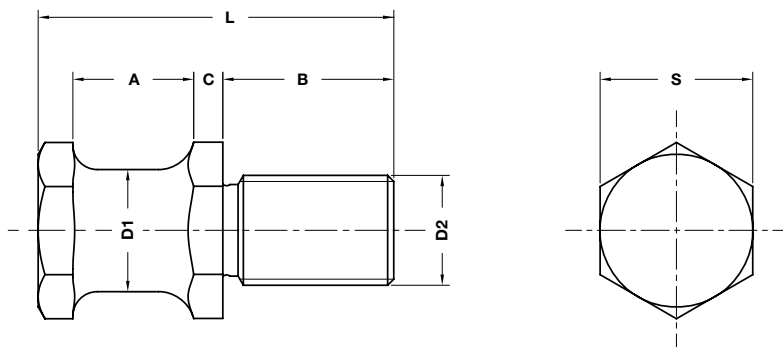

ORDER EXAMPLE	Art.	D1-32
	B02.05.	32

OMCR CODE	Max load (kg)	Max die weight (kg)	D1	D2	A	B	C	L	S
B02.05.16	320	640	16	M16	20	28	5,5	58	24
B02.05.20	500	1000	20	M20	22	34	6,5	68	30
B02.05.25	1000	2000	25	M24	25	38	8	78	36
B02.05.32	1500	3000	32	M30	32	45	10	95	41
B02.05.40	2500	5000	40	M36	40	56	12	118	50

LIFTING PIN WITH ROPE SAFETY STOP TRAGSCHRAUBE MIT SEILSICHERUNG PERNO DI SOLLEVAMENTO CON SICUREZZA FERMAFUNE

Patent-Nr.: TO2003A000468



Respect the max load
Maximale Nutzlast beachten
Rispettare il carico Max

WARNING - ACHTUNG - ATTENZIONE:

For safety reason, please consider always that the weight of the die has to be supported by just 2 lifting pins.

Aus Sicherheitsgründen stets berücksichtigen, dass zwei Tragschrauben das gesamte Werkzeuggewicht tragen müssen.

Per ragioni di sicurezza, considerare sempre che il peso dello stampo deve essere sopportato da 2 soli perni.

Notes

Material: CK45
700÷800 N/mm²

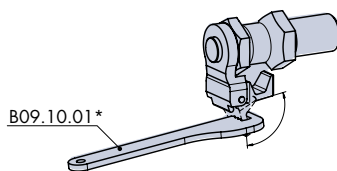
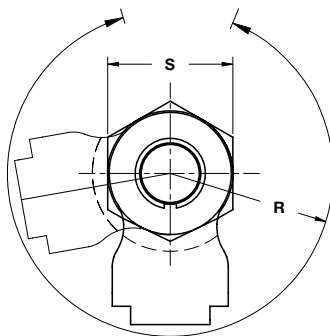
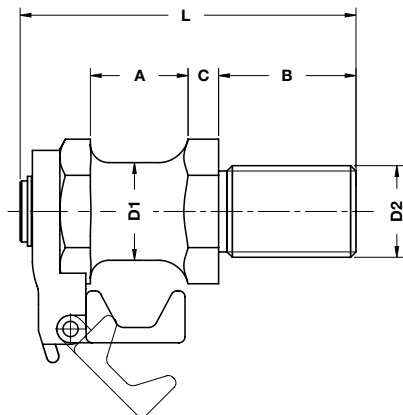

*To open rope stop safety use key B09.10.01

ORDER EXAMPLE	Art.	D1=32
	B02.06.	32

OMCR CODE	Max load (kg)	Max die weight (kg)	D1	D2	A	B	C	L	S	R
B02.06.20	500	1000	20	M20	22	34	6,5	80	30	38
B02.06.25	1000	2000	25	M24	25	38	8	93	36	42
B02.06.32	1500	3000	32	M30	32	45	10	110	41	50
B02.06.40	2500	5000	40	M36	40	56	12	132	50	57

Lifting Elements

LIFTING PIN VDI 3366 TRAGBOLZEN MIT FALLRINGSICHERUNG VDI 3366 PERNO DI SOLLEVAMENTO VDI 3366



Respect the max load
Maximale Nutzlast beachten
Rispettare il carico Max

WARNING - ACHTUNG - ATTENZIONE:
For safety reason, please consider always that the weight of the die has to be supported by just 2 lifting pins.

Aus Sicherheitsgründen stets berücksichtigen, dass zwei Tragbolzen das gesamte Werkzeuggewicht tragen müssen.

Per ragioni di sicurezza, considerare sempre che il peso dello stampo deve essere sopportato da 2 soli perni.

According - Nach - Secondo:
VDI3366 ed. 03/1997

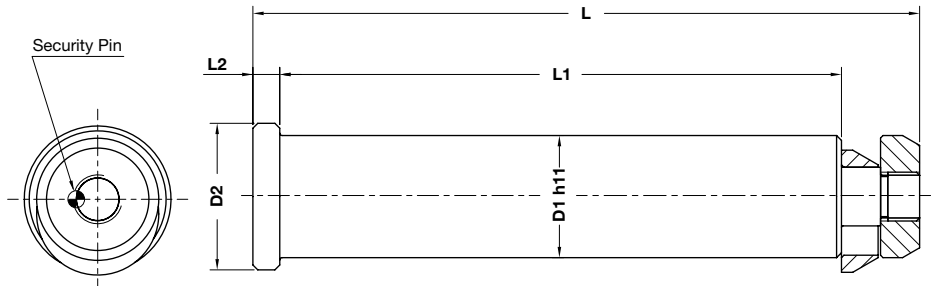
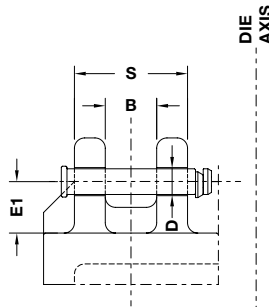

ORDER EXAMPLE	Art.	D1=76
	B02.10.	76

OMCR CODE	Max load (kg)	Max die weight (kg)	B	D	D1	D2	E1	L	L1	L2	S	Material
B02.10.32	3200	6400	60	34	32	40	63	175	145	10	140	CK45
B02.10.40	5000	10000	80	42	40	50	80	225	188	10	180	CK45
B02.10.50	8000	16000	100	52	50	60	100	273	230	11	220	CK45
B02.10.63	12500	25000	120	65	63	75	125	347	295	14	280	CK45
B02.10.76	31500	63000	140	78	76	95	160	422	360	15	340	42CrMo4 + QT

LIFTING PIN VW/AUDI TRAGBOLZEN MIT FALLRINGSICHERUNG UND FEDER NACH VW/AUDI-NORM PERNO DI SOLLEVAMENTO VW/AUDI



Respect the max load
Maximale Nutzlast beachten
Rispettare il carico Max

WARNING - ACHTUNG - ATTENZIONE:

For safety reason, please consider always that the weight of the die has to be supported by just 2 lifting pins.

Aus Sicherheitsgründen stets berücksichtigen, dass zwei Tragbolzen das gesamte Werkzeuggewicht tragen müssen.

Per ragioni di sicurezza, considerare sempre che il peso dello stampo deve essere sopportato da 2 soli perni.

According - Nach - Secondo:
39D866 VW ed. 09/2011

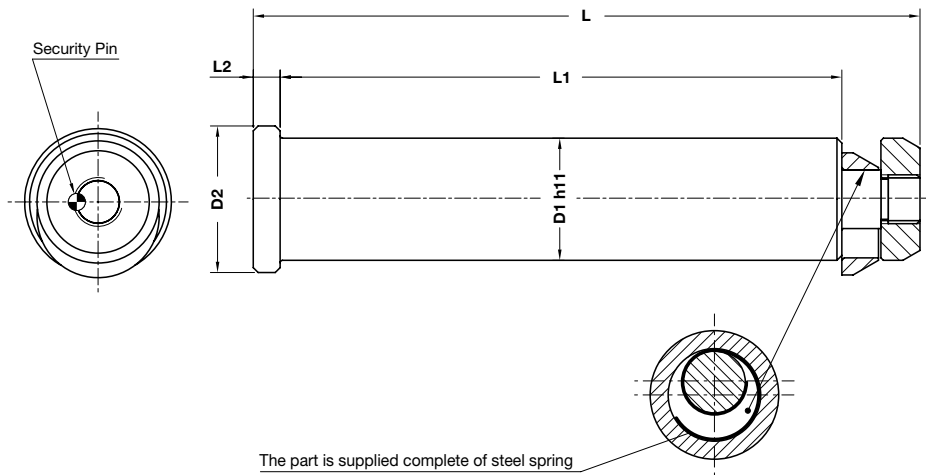
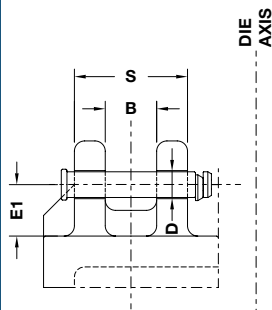

ORDER EXAMPLE	Art.	D1=76
	B02.11.	76

OMCR CODE	Max load (kg)	Max die weight (kg)	B	D	D1	D2	E1	L	L1	L2	S	Material
B02.11.32	3200	6400	60	34	32	40	63	175	145	10	140	CK45
B02.11.40	5000	10000	80	42	40	50	80	225	188	10	180	CK45
B02.11.50	8000	16000	100	52	50	60	100	273	230	11	220	CK45
B02.11.63	12500	25000	120	65	63	75	125	347	295	14	280	CK45
B02.11.76	31500	63000	140	78	76	95	160	422	360	15	340	42CrMo4 + QT

Lifting Elements

LIFTING PIN MERCEDES-BENZ TRAGBOLZEN MIT FALLRINGSICHERUNG UND FEDER NACH MERCEDES-BENZ NORM PERNO DI SOLLEVAMENTO MERCEDES-BENZ



Respect the max load
Maximale Nutzlast beachten
Rispettare il carico Max

WARNING - ACHTUNG - ATTENZIONE:

For safety reason, please consider always that the weight of the die has to be supported by just 2 lifting pins.

Aus Sicherheitsgründen stets berücksichtigen, dass zwei Tragbolzen das gesamte Werkzeuggewicht tragen müssen.

Per ragioni di sicurezza, considerare sempre che il peso dello stampo deve essere sopportato da 2 soli perni.

According - Nach - Secondo:
VDI3366

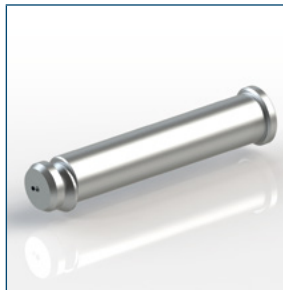
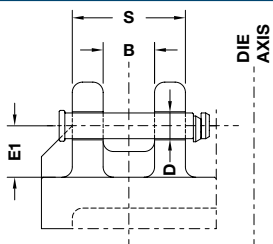

Notes

Material: 42CrMo4 + QT

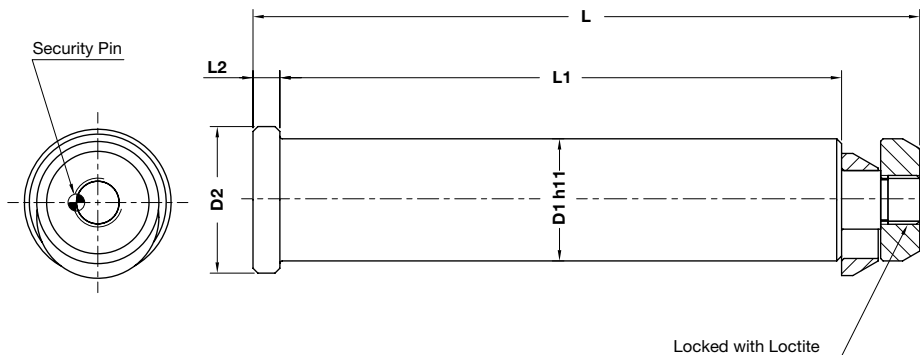

ORDER EXAMPLE	Art.	D1=76
	B02.12.	76

OMCR CODE	Max load (kg)	Max die weight (kg)	B	D	D1	D2	E1	L	L1	L2	S
B02.12.32	3200	6400	60	34	32	40	63	175	145	10	140
B02.12.40	5000	10000	80	42	40	50	80	225	188	10	180
B02.12.50	8000	16000	100	52	50	60	100	273	230	11	220
B02.12.63	12500	25000	120	65	63	75	125	347	295	14	280
B02.12.76	31500	63000	140	78	76	95	160	422	360	15	340

LIFTING PIN FCA TRAGBOLZEN MIT FALLRINGSICHERUNG UND FEDER NACH FCA NORM PERNO DI SOLLEVAMENTO FCA



Respect the max load
Maximale Nutzlast beachten
Rispettare il carico Max

WARNING - ACHTUNG - ATTENZIONE:

For safety reason, please consider always that the weight of the die has to be supported by just 2 lifting pins.

Aus Sicherheitsgründen stets berücksichtigen, dass zwei Tragbolzen das gesamte Werkzeuggewicht tragen müssen.

Per ragioni di sicurezza, considerare sempre che il peso dello stampo deve essere sopportato da 2 soli perni.

According - Nach - Secondo:
095.25.

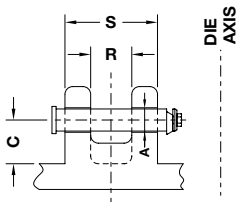

Notes

Material: CK45



Only for replacement
Nur für Reparatur
Solo per riparazione

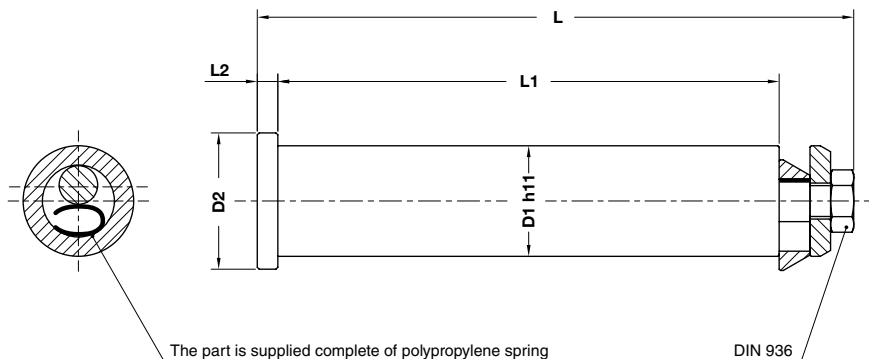

Art.	D1=53	Type
B02.15.	53	C

OMCR CODE	Max load (kg)	Max die weight (kg)	Type	A	C	D1	D2	L	L1	L2	R	S
B02.15.43	5000	10000	-	45	85	43	53	233	195	8	80	180
B02.15.53	8000	16000	-	55	105	53	65	282	235	10	100	220
B02.15.53C	8000	16000	C	55	75	53	65	227	180	10	65	165
B02.15.63	12000	24000	-	65	130	63	78	352,5	295	12	120	280
B02.15.63C	13000	26000	C	65	100	63	78	272,5	215	12	80	200
B02.15.78	30000	60000	-	81	150	78	95	421,5	355	14	140	340

LIFTING PIN FCA TRAGBOLZEN MIT FALLRINGSICHERUNG UND FEDER NACH FCA NORM PERNO DI SOLLEVAMENTO FCA



Respect the max load
Maximale Nutzlast beachten
Rispettare il carico Max

WARNING - ACHTUNG - ATTENZIONE:

For safety reason, please consider always that the weight of the die has to be supported by just 2 lifting pins.

Aus Sicherheitsgründen stets berücksichtigen, dass zwei Tragbolzen das gesamte Werkzeuggewicht tragen müssen.

Per ragioni di sicurezza, considerare sempre che il peso dello stampo deve essere sopportato da 2 soli perni.

According - Nach - Secondo:
095.25.

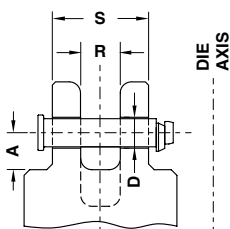

Notes

Material: 42CrMo4 + QT



FORM A

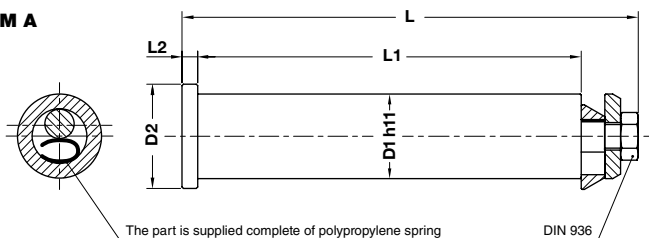

FORM B

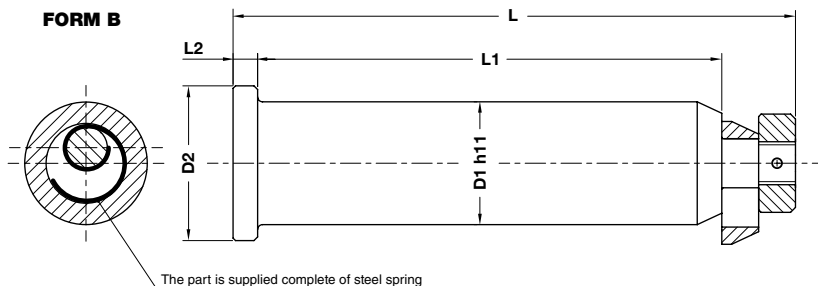

ORDER EXAMPLE	Art.	D1=50
	B02.16.	50

OMCR CODE	Max load (kg)	Max die weight (kg)	A	D	D1	D2	L	L1	L2	R	S	FORM
B02.16.29	4000	8000	60	30	29	38	178.5	150	6	60	140	A
B02.16.33	7000	14000	65	35	33	43	200.5	170	6	60	160	A
B02.16.50	10000	20000	70	52	50	63	230	190	10	85	185	B
B02.16.63	20000	40000	100	65	63	76	320	280	10	110	270	B
B02.16.80	40000	80000	105	82	80	89	370	320	15	110	310	B

LIFTING PIN FORD
TRAGBOLZEN MIT FALLRINGSICHERUNG UND FEDER NACH FORD NORM
PERNO DI SOLLEVAMENTO FORD



Respect the max load
 Maximale Nutzlast beachten
 Rispettare il carico Max

WARNING - ACHTUNG - ATTENZIONE:
 For safety reason, please consider always that the weight of the die has to be supported by just 2 lifting pins.

Aus Sicherheitsgründen stets berücksichtigen, dass zwei Tragbolzen das gesamte Werkzeuggewicht tragen müssen.

Per ragioni di sicurezza, considerare sempre che il peso dello stampo deve essere sopportato da 2 soli perni.

According - Nach - Secondo:
 W-DX 12-04

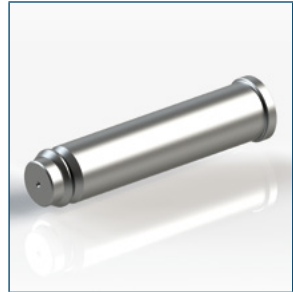
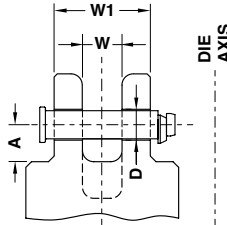

Notes

Material: 42CrMo4 + QT

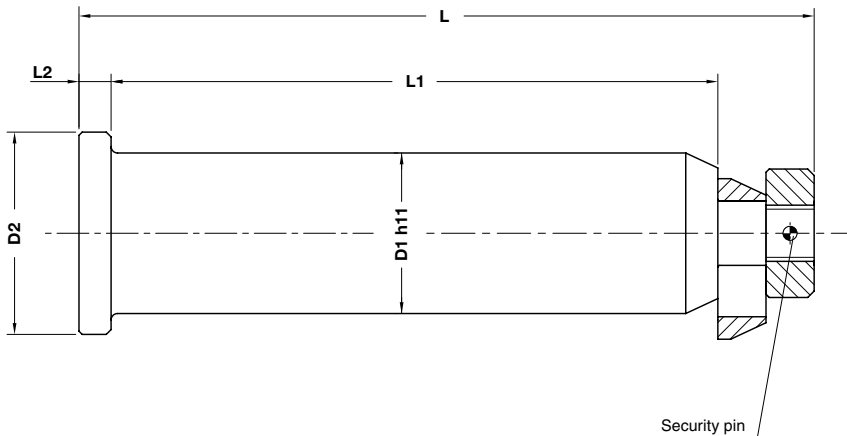

ORDER EXAMPLE	Art.	D1=50
	B02.22.	50

OMCR CODE	Max load (kg)	Max die weight (kg)	A	D	D1	D2	L	L1	L2	W	W1
B02.22.35	1500	3000	60	37	35	45	165	125	10	50	110
B02.22.50	5500	10050	130	52	50	63	230	190	10	70	170
B02.22.63	23000	45500	145	65	63	76	320	280	10	100	260
B02.22.80	30000	60000	145	82	80	89	370	320	15	100	300

Lifting Elements

LIFTING PIN NISSAN TRAGBOLZEN MIT FALLRINGSICHERUNG UND FEDER NACH NISSAN NORM PERNO DI SOLLEVAMENTO NISSAN



Respect the max load
Maximale Nutzlast beachten
Rispettare il carico Max

WARNING - ACHTUNG - ATTENZIONE:
For safety reason, please consider always that the weight of the die has to be supported by just 2 lifting pins.

Aus Sicherheitsgründen stets berücksichtigen, dass zwei Tragbolzen das gesamte Werkzeuggewicht tragen müssen.

Per ragioni di sicurezza, considerare sempre che il peso dello stampo deve essere sopportato da 2 soli perni.

According - Nach - Secondo:
K1 140-40+80

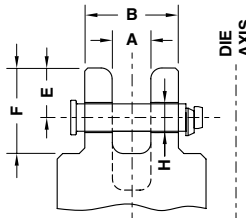

Notes

Material: 42CrMo4 + QT

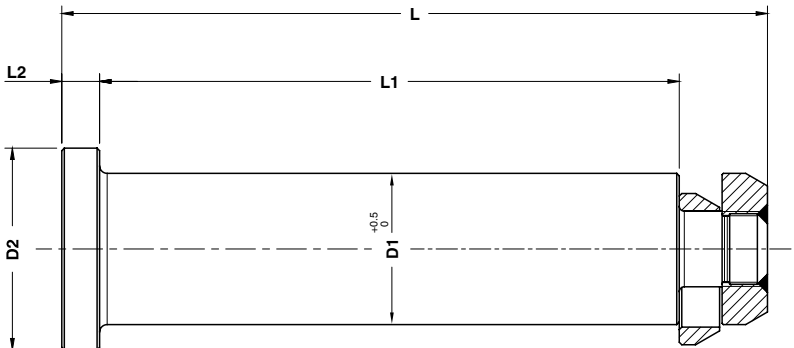

ORDER EXAMPLE	Art.	D1=50
	B02.23.	50

OMCR CODE	Max load (kg)	Max die weight (kg)	A	B	H	D1	D2	E	F	L	L1	L2
B02.23.40	2000	4000	50	150	41,5	40	60	50	110	210	160	15
B02.23.50	3000	6000	70	210	51,5	50	70	75	150	270	220	15
B02.23.60	5000	10000	80	220	61,5	60	80	100	195	280	230	15
B02.23.70	7500	15000	80	240	71,5	70	90	110	210	300	250	15
B02.23.80	17500	35000	90	290	82	80	100	120	230	350	300	15

LIFTING PIN OPEL-GM TRAGBOLZEN MIT FALLRINGSICHERUNG UND FEDER NACH OPEL-GM NORM PERNO DI SOLLEVAMENTO OPEL-GM



Respect the max load
Maximale Nutzlast beachten
Rispettare il carico Max

WARNING - ACHTUNG - ATTENZIONE:

For safety reason, please consider always that the weight of the die has to be supported by just 2 lifting pins.

Aus Sicherheitsgründen stets berücksichtigen, dass zwei Tragbolzen das gesamte Werkzeuggewicht tragen müssen.

Per ragioni di sicurezza, considerare sempre che il peso dello stampo deve essere sopportato da 2 soli perni.

According - Nach - Secondo:
15.30.00 ed. 05/2007

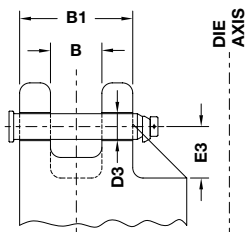

Notes

Material: 42CrMo4 + QT

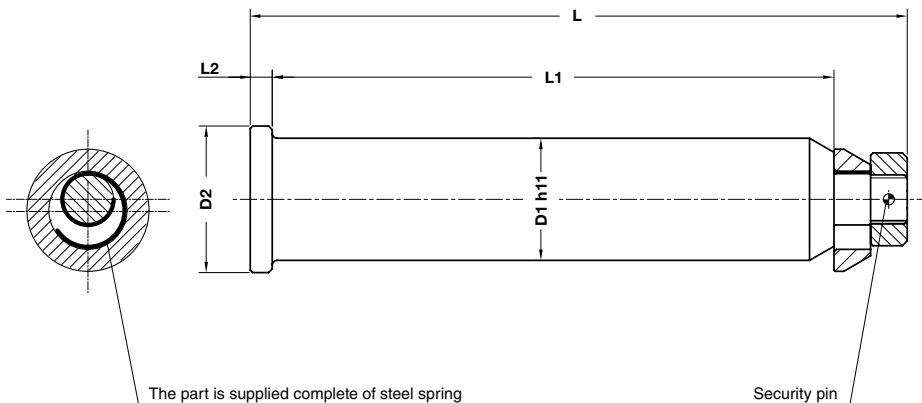

Lifting Elements

ORDER EXAMPLE	Art.	D1=80
	B02.26.	80

OMCR CODE	Max load (kg)	Max die weight (kg)	B	B1	D1	D2	D3	E3	L	L1	L2
B02.26.32	3400	6800	70	150	32	40	34	65	177	155	5
B02.26.40	5650	11300	80	180	40	50	42	85	220	188	7
B02.26.50	8950	17900	100	220	50	60	52	100	270	230	9
B02.26.63	14350	28700	120	280	63	75	65	125	342	295	16
B02.26.80	26700	53400	120	320	80	89	82	160	387	335	16

LIFTING PIN PSA-RENAULT TRAGBOLZEN MIT FALLRINGSICHERUNG UND FEDER NACH PSA-RENAULT NORM PERNO DI SOLLEVAMENTO PSA-RENAULT



Respect the max load
Maximale Nutzlast beachten
Rispettare il carico Max

WARNING - ACHTUNG - ATTENZIONE:

For safety reason, please consider always that the weight of the die has to be supported by just 2 lifting pins.

Aus Sicherheitsgründen stets berücksichtigen, dass zwei Tragbolzen das gesamte Werkzeuggewicht tragen müssen.

Per ragioni di sicurezza, considerare sempre che il peso dello stampo deve essere sopportato da 2 soli perni.

According - Nach - Secondo:
EM24.50.400 ed. 07/2006
EM24.59.950 ed. 07/2006

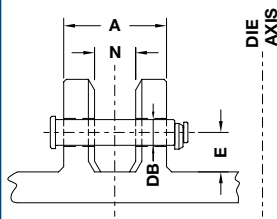

Notes

Material: St52

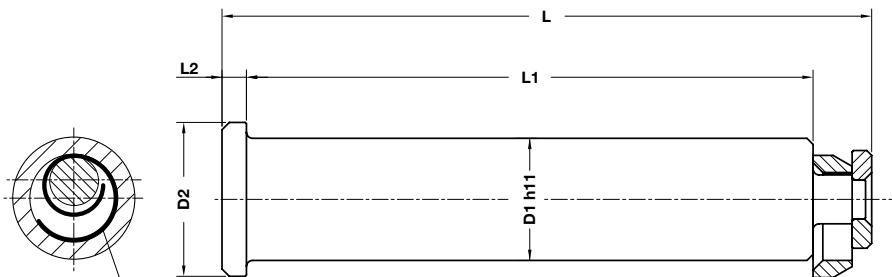

The part is supplied complete of steel spring

ORDER EXAMPLE	Art.	D1=50
	B02.30.	50

OMCR CODE	Max load (kg)	Max die weight (kg)	A	E	DB	D1	D2	L	L1	L2	N
B02.30.32	6000	12000	125	55	34	32	40	154	132	6	50
B02.30.40	9000	18000	160	70	42	40	50	197,5	170	8	65
B02.30.50	14000	28000	200	90	52	50	63	247,5	212	10	80
B02.30.63	22500	45000	250	100	65	63	80	309	265	12	100

LIFTING PIN VOLVO TRAGBOLZEN MIT FALLRINGSICHERUNG UND FEDER NACH VOLVO NORM PERNO DI SOLLEVAMENTO VOLVO



Respect the max load
Maximale Nutzlast beachten
Rispettare il carico Max

WARNING - ACHTUNG - ATTENZIONE:

For safety reason, please consider always that the weight of the die has to be supported by just 2 lifting pins.

Aus Sicherheitsgründen stets berücksichtigen, dass zwei Tragbolzen das gesamte Werkzeuggewicht tragen müssen.

Per ragioni di sicurezza, considerare sempre che il peso dello stampo deve essere sopportato da 2 soli perni.

According - Nach - Secondo:
BCD8271,81 01/2015

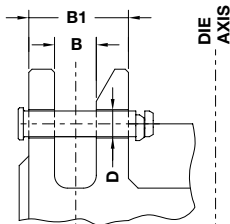

Notes

Material: St52

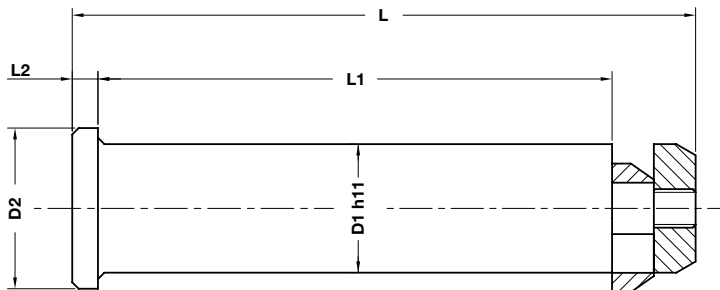

Lifting Elements

ORDER EXAMPLE	Art.	D1=63	Type
	B02.35.	63	C

OMCR CODE	Max load (kg)	Max die weight (kg)	Type	A	B	B1	C	D	D1	D2	E	L	L1	L2
B02.35.40	2500	5000	-	40	65	155	50	42	40	50	100	195	160	8
B02.35.63C	8000	16000	C	60	100	220	60	65	63	75	125	285	230	14
B02.35.63	12000	24000	-	80	100	260	80	65	63	75	125	327	275	14
B02.35.80	20000	40000	-	100	120	320	100	82	80	95	180	402	340	15

REPLACEMENT LIFTING PIN FOR LIFTING BRACKET BMW ERSATZTRAGBOLZEN FÜR TRAGWANGE BMW PERNO DI RICAMBIO PER STAFFA DI SOLLEVAMENTO BMW



Respect the max load
Maximale Nutzlast beachten
Rispettare il carico Max

WARNING - ACHTUNG - ATTENZIONE:
For safety reason, please consider always that the weight of the die has to be supported by just 2 lifting pins.

Aus Sicherheitsgründen stets berücksichtigen, dass zwei Tragbolzen das gesamte Werkzeuggewicht tragen müssen.

Per ragioni di sicurezza, considerare sempre che il peso dello stampo deve essere sopportato da 2 soli perni.

According - Nach - Secondo:
B01.20

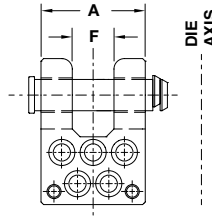

Notes

Material:

See table - siehe Tabelle - vedi tabella

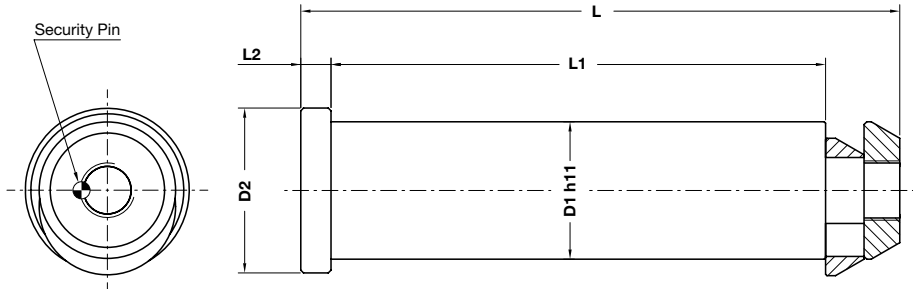

ORDER EXAMPLE	Art.	D1=80	Type
	B02.40.	80	A

OMCR CODE	Max load (kg)	Max die weight (kg)	Type	A	F	D1	D2	L	L1	L2	Material
B02.40.30	3200	6400	-	126	50	30	40	158	129	10	CK45
B02.40.40	5000	10000	-	150	60	40	50	187	155	10	CK45
B02.40.50	8000	16000	-	175	75	50	60	220	180	11	CK45
B02.40.60	12500	25000	-	200	80	60	70	246	205	11	CK45
B02.40.80	18000	36000	-	250	100	80	90	305	255	12	CK45
B02.40.80A	25000	50000	A	300	120	80	90	360	310	12	42CrMo4 + QT
B02.40.80B	31500	63000	B	345	135	80	90	405	355	22	42CrMo4 + QT

REPLACEMENT LIFTING PIN FOR LIFTING BRACKET FCA ERSATZTRAGBOLZEN FÜR TRAGWANGE FCA PERNO DI RICAMBIO PER STAFFA DI SOLLEVAMENTO FCA



Respect the max load
Maximale Nutzlast beachten
Rispettare il carico Max

WARNING - ACHTUNG - ATTENZIONE:

For safety reason, please consider always that the weight of the die has to be supported by just 2 lifting pins.

Aus Sicherheitsgründen stets berücksichtigen, dass zwei Tragbolzen das gesamte Werkzeuggewicht tragen müssen.

Per ragioni di sicurezza, considerare sempre che il peso dello stampo deve essere sopportato da 2 soli perni.

According - Nach - Secondo:
B01.15

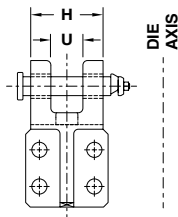

Notes

Material: CK45

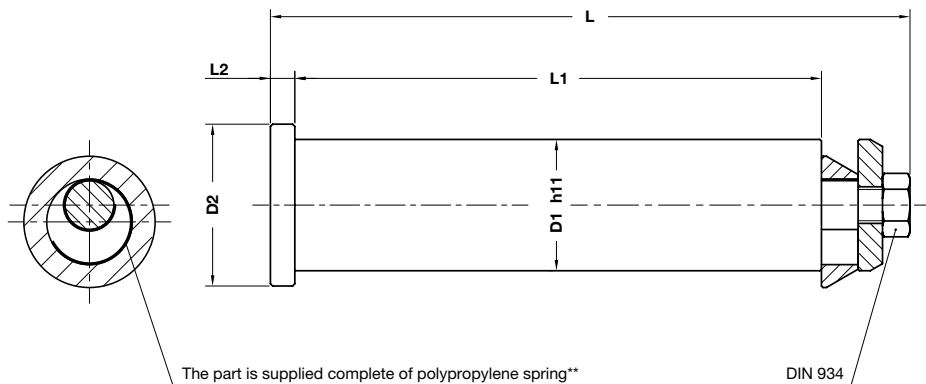

The part is supplied complete of polypropylene spring**

DIN 934

ORDER EXAMPLE	Art.	D1=60
	B02.42.	60

OMCR CODE	Max load (kg)	Max die weight (kg)	D1	D2	H	L	L1	L2	U
B02.42.15	600	1200	15,6	25	70	102,5	77	6	30
B02.42.20	1000	2000	20,6	30	79	113,5	86	6	35
B02.42.25	2000	4000	25,6	35	90	128,5	100	6	40
B02.42.33	4000	8000	33	43	125	166,5	135	6	55
B02.42.43	7000	14000	43	53	160	210,5	175	8	60

REPLACEMENT LIFTING PIN FOR LIFTING BRACKET VW/AUDI ERSATZTRAGBOLZEN FÜR TRAGWANGE VW/AUDI PERNO DI RICAMBIO PER STAFFA DI SOLLEVAMENTO VW/AUDI



Respect the max load
Maximale Nutzlast beachten
Rispettare il carico Max

WARNING - ACHTUNG - ATTENZIONE:

For safety reason, please consider always that the weight of the die has to be supported by just 2 lifting pins.

Aus Sicherheitsgründen stets berücksichtigen, dass zwei Tragbolzen das gesamte Werkzeuggewicht tragen müssen.

Per ragioni di sicurezza, considerare sempre che il peso dello stampo deve essere sopportato da 2 soli perni.

According - Nach - Secondo:
B01.24

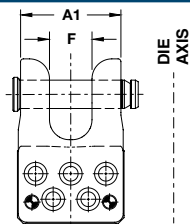

Notes

Material: CK45



WEB

WEB

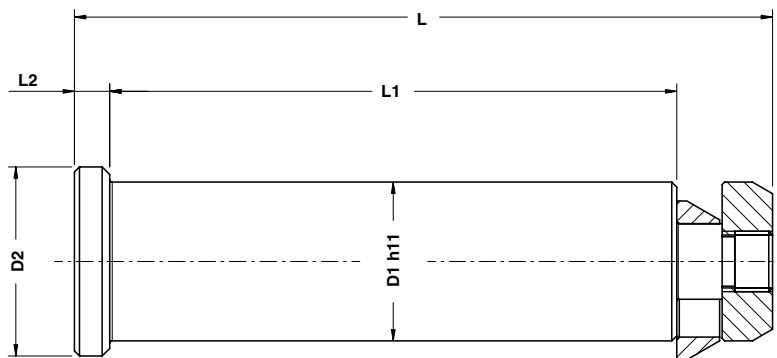

ORDER EXAMPLE	Art.	D1
	B02.44.	63

OMCR CODE	Max load (kg)	Max die weight (kg)	A1	D1	D2	F	L	L1	L2
B02.44.50	8000	16000	177	50	60	75	221	182	11
B02.44.63	12500	25000	220	63	75	80	277	225	14

ROTATING EYEBOLT H.T. - RINGSCHRAUBE H.T. - GOLFARE GIREVOLE H.T.

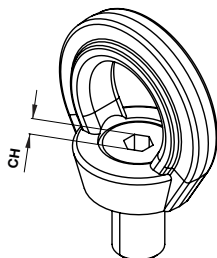
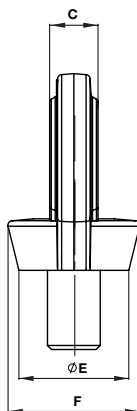
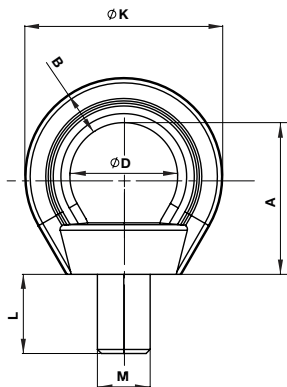

FORESEEN USE

Turning eyebolt needed to lift loads to assemble to the load itself with specific threaded hole generally used to turn or tilt heavy loads.

- Safety coefficient 4 in all loading directions
- Designed, tested and certified in compliance with the technical directives GS-OA 15-04 EN 1677
- Suitable for safe lifting in compliance with the machinery directive 2006/42/EC
- Can be oriented at 360°
- Tested at 100 % magnaflux
- Tested at 20.000 stress cycles
- Ideal for fastening at 90°
- Captive screws
- On the axial pull there can be variation of +/-5° with a 10% decrease in capacity

Accordingly with the requirements of "DGUV – German institution for security" please use the devise with the screw supplied, if replaced OMCR Srl disclaims any and all responsibility or liability.

Not suitable for continuous rotation during loading

CONFIGURATION NOT RECOMMENDED

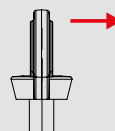

	Art.	Screw Dim.	OPTION KEY
	B03.10.	010	W

OMCR CODE	Size (mm)	W.L.L. (t)	A (mm)	B (mm)	C (mm)	D (Ømm)	E (Ømm)	F (mm)	K (mm)	L (mm)	CH (mm)	Weight (Kg)
B03.10.006	M06	0,1	27	9,5	7	20	23	27,7	37	9	6	0,08
B03.10.008	M08	0,3	33,7	10	9,8	25	25,5	30	46	12	6	0,120
B03.10.010	M10	0,4	33,7	10	9,8	25	25,5	30	46	15	6	0,120
B03.10.012	M12	0,75	41,5	12,5	11,5	30	30,6	36,5	55,5	18	8	0,200
B03.10.016	M16	1,5	49,5	14,5	15,7	35	36,5	42	64,5	24	10	0,350
B03.10.020	M20	2,3	58	16	18	40	42	52,5	74,5	30	12	0,600
B03.10.024	M24	3,2	69	20,5	22	49	50	61	90	36	12	1,000
B03.10.030	M30	4,5	86	25,5	28	60	66	75	111	45	17	2,000
B03.10.036	M36	7	105	32	30	74	77	96,5	135	55	22	3,400
B03.10.042	M42	9	118	38	37	82	87	110	158	65	24	5,700
B03.10.048	M48	12	137	43	38	95	102	124,5	180	72	27	8,500

WORKING LOAD LIMIT W.L.L. (t)

OMCR CODE	Size (mm)												Max tightening couple (Nm)
		0°	0°	90°	90°	0-45°	45°-60°	Asymm	0°-45°	45°-60°	Asymm		
		Single leg	2 legs	Single leg	2 legs	2 legs		3/4 legs					
B03.10.006	M06	0,5	1	0,1	0,2	0,14	0,1	0,1	0,21	0,15	0,1	6	
B03.10.008	M08	1	2	0,3	0,6	0,42	0,3	0,3	0,63	0,45	0,3	8	
B03.10.010	M10	1	2	0,4	0,8	0,56	0,4	0,4	0,84	0,6	0,4	16	
B03.10.012	M12	2	4	0,75	1,5	1	0,75	0,75	1,6	1,12	0,75	25	
B03.10.016	M16	4	8	1,5	3	2	1,5	1,5	3,15	2,25	1,5	60	
B03.10.020	M20	6	12	2,3	4,6	3,22	2,3	2,3	4,83	3,45	2,3	110	
B03.10.024	M24	8	16	3,2	6,4	4,48	3,2	3,2	6,7	4,8	3,2	195	
B03.10.030	M30	12	24	4,5	9	6,3	4,5	4,5	9,4	6,7	4,5	320	
B03.10.036	M36	16	32	7	14	9,8	7	7	14,7	10,5	7	585	
B03.10.042	M42	24	45	9	18	12,6	9	9	18,9	13,5	9	920	
B03.10.048	M48	32	64	12	24	16,8	12	12	25,2	18	12	1590	

Lifting Elements

B03.10

KEY - SCHLÜSSEL - CHIAVE

	Art.	Thread=M10
	B03.10.	C10

OMCR CODE	Size (mm)	OMCR CODE	Size (mm)
B03.10.C06	M06	B03.10.024	M24
B03.10.C08	M08	B03.10.030	M30
B03.10.C10	M10	B03.10.036	M36
B03.10.C12	M12	B03.10.042	M42
B03.10.C16	M16	B03.10.048	M48
B03.10.C20	M20		



ROTATING EYEBOLT WITH CLAMP - LASTBOCK - GOLFARE GIREVOLE CON STAFFA

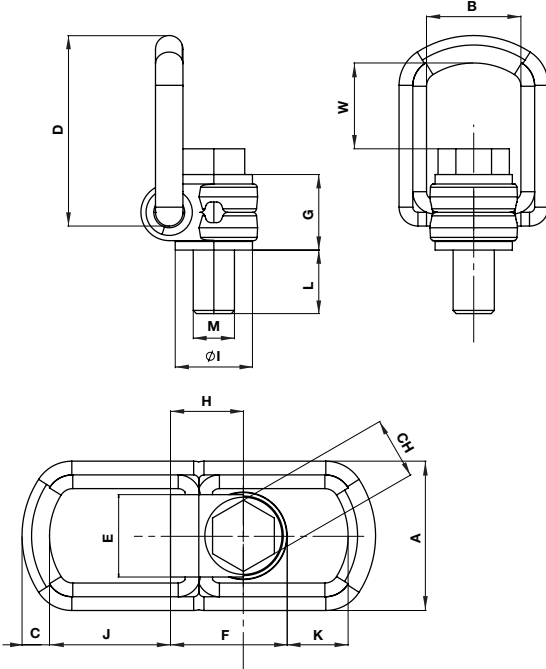

Notes

PULL AT 90° with minimum overall dimensions.

Available on demand **-40°C**.



FORESEEN USE
Anchorage point for load lifting.

- Safety coefficient 4 in all loading directions
- Designed, tested and certified in compliance with the technical directives GS-OA 15-04 – EN 1677
- Suitable for safe lifting in compliance with the machinery directive 2006/42/EC
- Can be oriented at 360°
- Tested at 100 % magnaflux
- Tested at 20.000 stress cycles
- The screw is protected with the GEOMET system which guarantees lasting protection in time
- Ideal for fastening at 90°
- Captive screws.

Accordingly with the requirements of “DGUV – German institution for security” please use the device with the screw supplied, if replaced OMCR Srl disclaims any and all responsibility or liability.

Not suitable for continuous rotation during loading

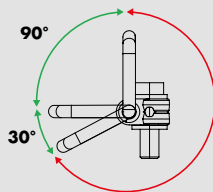

NOT ALLOWED

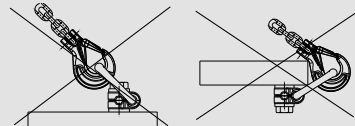



Art.	Screw Dim.
B03.15.	010

OMCR CODE	Size (mm)	W.L.L. (t)	A (mm)	B (mm)	C (mm)	D (mm)	E (mm)	F (mm)	G (mm)	H (mm)	I (mm)	L (mm)	W (mm)	J (mm)	K (mm)	Ch (mm)	Weight (Kg)
B03.15.008	M8	0,3	57	34	10	78	24	41	30	26,5	25	15	43	51	35	13	0,275
B03.15.010	M10	0,63	57	34	10	78	24	41	30	26,5	25	15	42	51	35	17	0,290
B03.15.012	M12	1	66	38	13,5	85	30	50	36	33	32	23	40	52	28	19	0,500
B03.15.016	M16	1,5	66	38	13,5	85	30	50	36	33	32	24	38	52	28	24	0,510
B03.15.020	M20	2,5	87	55	16	111	48	68	44	42,5	45	31	54	71	36	30	1,250
B03.15.024	M24	4	87	55	16	111	48	68	44	42,5	45	37	51	71	36	36	1,300
B03.15.030	M30	5	109	66	22,5	145	54	91	65	58,5	60	45	62	86	47	46	3,250
B03.15.036	M36	8	136	78	28	190	62	108	81	72,5	70	59	88	115	74	55	5,900
B03.15.042	M42	10	136	78	28	190	62	108	75	72,5	70	75	86	115	70	65	6,500
B03.15.142	M42	15	169	97	36	242	68	131	89	87,5	85	63	121	151	97	65	11,200
B03.15.048	M48	20	169	97	36	242	68	131	89	87,5	95	71	117	151	93	75	11,600

WORKING LOAD LIMIT W.L.L. (t)

OMCR CODE	Size (mm)	0°	0°	90°	90°	0-45°	45°- 60°	Asymm	0°- 45°	45°- 60°	Asymm	Max tightening couple (Nm)
		Single leg	2 legs	Single leg	2 legs	2 legs		3/4 legs				
B03.15.008	M8	0,3	0,6	0,3	0,6	0,42	0,3	0,3	0,63	0,45	0,3	30
B03.15.010	M10	0,63	1,26	0,63	1,26	0,88	0,63	0,63	1,32	0,95	0,63	60
B03.15.012	M12	1	2	1	2	1,4	1	1	2,1	1,5	1	100
B03.15.016	M16	1,5	3	1,5	3	2,1	1,5	1,5	3,15	2,25	1,5	150
B03.15.020	M20	2,5	5	2,5	5	3,5	2,5	2,5	5,25	3,75	2,5	250
B03.15.024	M24	4	8	4	8	5,6	4	4	8,4	6	4	400
B03.15.030	M30	5	10	5	10	7	5	5	10,5	7,5	5	500
B03.15.036	M36	8	16	8	16	11,2	8	8	16,8	12	8	800
B03.15.042	M42	10	20	10	20	14	10	10	21	15	10	925
B03.15.142	M42	15	30	15	30	21	15	15	31,5	22,5	15	1500
B03.15.048	M48	20	40	20	40	28	20	20	42	30	20	2000

ROTATING EYEBOLT H.T. - RINGSCHRAUBE H.T. - GOLFARE GIREVOLE H.T.

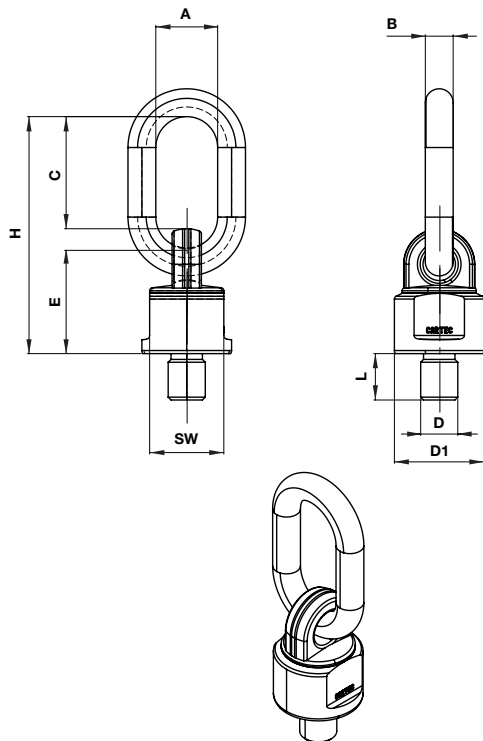

Notes

Can be oriented at **360°**.

Available on demand **-40°C**.

**CAN BE ORIENTED DURING
LOADING**



FORESEEN USE

Turning eyebolt needed to lift loads to assemble to the load itself with specific threaded hole generally used to turn or tilt heavy loads.

- Safety coefficient 4 in all loading directions
- Designed, tested and certified in compliance with the technical directives GS-OA 15-04 – EN 1677
- Suitable for safe lifting in compliance with the machinery directive 2006/42/EC
- Tested at 100 % magnaflux
- Tested at 20.000 stress cycles
- Can be oriented at 360° with self aligning tilting ring at 180°
- Assembled with spheres to make load orientation easier
- On the axial pull there can be variation of +/-5° with a 10% decrease in capacity

Accordingly with the requirements of "DGUV – German institution for security" please use the devise with the screw supplied, if replaced OMCR Srl disclaims any and all responsibility or liability.

**Movement suitable for
continuous rotation during loading**



Art.	Screw Dim.
B03.20.	010

OMCR CODE	Size (mm)	W.L.L. (t)	A (mm)	B (mm)	C (mm)	E (mm)	H (mm)	SW (mm)	D1 (mm)	Weight (Kg)
B03.20.008	M8x16	0,3	30	13	46	50	105	30	38	0,48
B03.20.010	M10x18	0,5	30	13	46	50	105	30	38	0,48
B03.20.012	M12x18	0,7	30	13	46	50	105	30	38	0,5
B03.20.016	M16x20	1,4	30	13	46	50	105	30	38	0,53
B03.20.020	M20x30	2,5	34	16	57	61	131	40	50	1,05
B03.20.024	M24x30	4	40	18	70	68	153	48	58	1,63
B03.20.030	M30x35	6,7	45	22	65	71	156	70	80	2,85
B03.20.036	M36x54	10	50	23	91	86	200	80	90	4,62
B03.20.042	M42x63	12,5	50	23	91	86	200	80	90	5,2
B03.20.045	M45x60	12,5	50	23	91	86	200	80	90	5,2
B03.20.048	M48x60	17	70	32	120	112	262	100	120	10,9
B03.20.056	M56x78	18	70	32	120	112	262	100	120	10,9
B03.20.064	M64x96	20 (25)	70	32	120	112	262	100	120	10,9
B03.20.090	M90x135	40	90	45	124	165	333	140	170	29

WORKING LOAD LIMIT W.L.L. (t)

OMCR CODE	Size (mm)	0°		90°		0-45°			45-60°			Max tightening couple (Nm)
		Single leg	2 legs	Single leg	2 legs	2 legs			3/4 legs			
B03.20.008	0,3 t-M8x16	0,6	1,2	0,3	0,6	0,42	0,3	0,3	0,63	0,45	0,3	16
B03.20.010	0,5 t-M10x18	1	2	0,5	1	0,75	0,5	0,5	1	0,75	0,5	16
B03.20.012	0,7 t-M12x18	1,4	2,4	0,7	1,4	1	0,7	0,7	1,4	1	0,7	28
B03.20.016	1,4 t-M16x20	2,8	5,6	1,4	2,8	2	1,4	1,4	3	2,1	1,4	70
B03.20.020	2,5 t-M20x30	5	10	2,5	5	3,5	2,5	2,5	5,3	3,7	2,5	135
B03.20.024	4 t-M24x30	8	16	4	8	5,6	4	4	8,4	6	4	230
B03.20.030	6,7 t-M30x35	12	24	6,7	13,4	9,4	6,7	6,7	14	10	6,7	465
B03.20.036	10 t-M36x54	15	30	10	20	14	10	10	21,2	15	10	814
B03.20.042	12,5 t-M42x63	15	30	12,5	25	17,5	12,5	12,5	26,2	18,7	12,5	1304
B03.20.045	16 t-M45x60	25	50	17	34	23,5	17	17	31,5	22,4	15	1670
B03.20.048	17 t-M48x60	25	50	18	36	25,2	18	18	35,7	25,5	17	1981
B03.20.056	18 t-M56x78	25	50	18	36	25,2	18	18	37	27	18	3000
B03.20.064	20 t-M64x96	25	50	20	40	28	20	20	42,5	30	20	4738
B03.20.090	40 t-M90x135	50	100	40	80	56	40	40	85	60	40	14000

BUSH FOR LIFTING PIN VDI-BAK
BUCHSE FÜR TRAGBOLZEN VDI-BAK
BOCCOLA PER PERNO DI SOLLEVAMENTO VDI-BAK

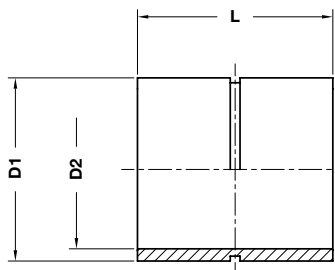

FORM A

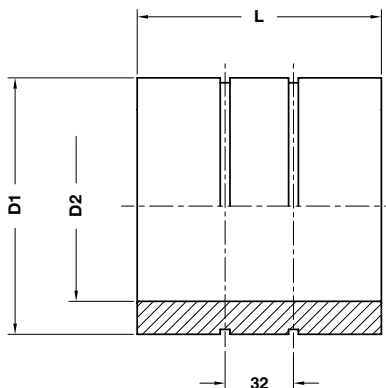

FORM B

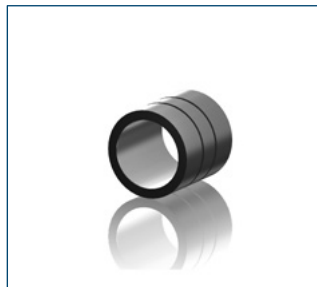

Application Example

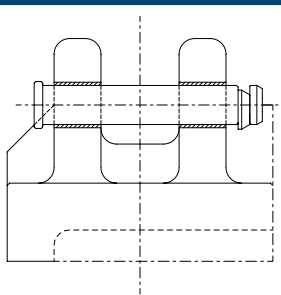

Notes

Material: Si35



Art.	D1	D2	L
B08.11.	044	34	040

OMCR CODE	D1	D2	L	FORM
B08.11.04434040	44	34	40	A
B08.11.05242050	52	42	50	A
B08.11.06252060	62	52	60	A
B08.11.07565080	75	65	80	A
B08.11.10078100	100	78	100	B
B08.11.10578100	105	78	100	B

THREADED STEEL INSERT GEWINDEINSATZ AUS STAHL INSERTO FILETTATO IN ACCIAIO

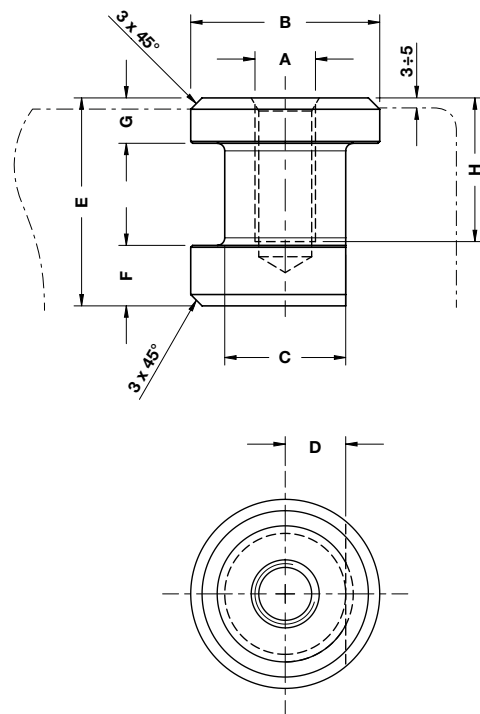

Inserts are to be used in cast iron die only
(do not use in cast steel).

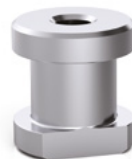

STOCK



Application Example

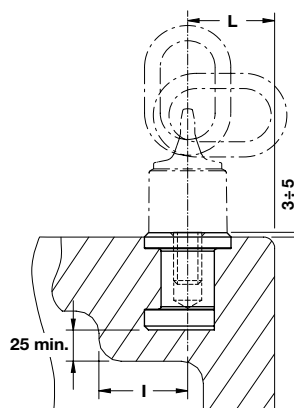

Notes

Material: 42CrMo4 + QT

ORDER EXAMPLE	Art.	A
	B08.20.	M20

OMCR CODE	Max load 1 point (kg)	Max load 2÷4 point (kg)	A	B	C	D	E	F	G	H	I	L
B08.20.M16	1000	2000	M16	50	32	16	55	16	12	42	60	60
B08.20.M20	2100	4200	M20	65	36	18	65	16	12	47	70	70
B08.20.M24	3000	6000	M24	65	40	20	75	16	12	57	80	80
B08.20.M30	5000	10000	M30	85	60	30	90	20	20	67	100	100
B08.20.M36	6500	13000	M36	107	80	40	100	22	22	77	110	110
B08.20.M42	7200	14400	M42	107	80	40	130	25	25	95	120	120
B08.20.M48	8000	16000	M48	107	80	40	150	30	30	110	130	130

ROPE SAFETY STOP OPENING KEY
SCHLÜSSEL FÜR SEILSICHERUNG
CHIAVE PER APERTURA SICUREZZA FERMAFUNNE

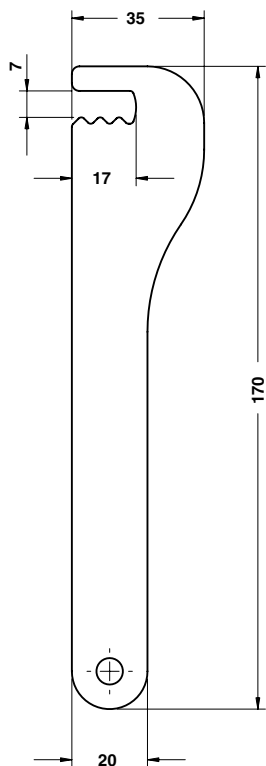

Application Example

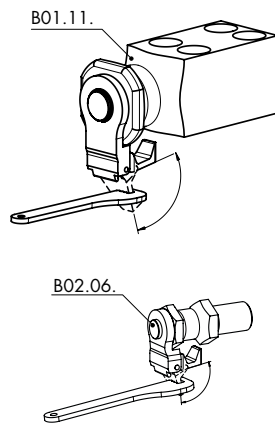

Notes

Material: CK45
 To use for B01.11. - B02.06.

	Art.
	B09.10.01

OMCR CODE

B09.10.01



